

MAC 4300V

AM/FM RECEIVER

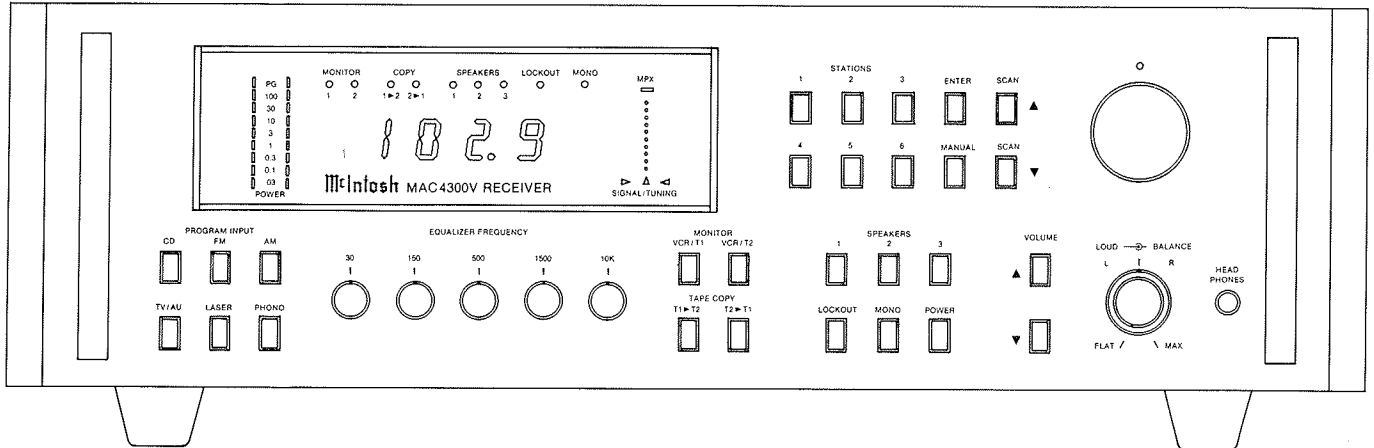

CONTENTS

Performance Specifications.....	2 - 3	Section 7 - Control Logic.....	28 - 33
Mechanical Views.....	3 - 4	Remote Receiver	
Notes.....	5	Switching Logic	
Block Diagrams - AM/FM Tuner Section.....	5 - 6	Section 8 - Keyboards.....	31 - 33
Pre-amp/Amplifier Section		Program Input	
Section Locations.....	7	Tuner	
Section 1 - Interconnection Diagram.....	8 - 10	Function	
AC Line Input		Section 9 - Power Display.....	34 - 35
Front Panel and Trim Parts List.....	11	Section 10 - Frequency Counter.....	36 - 38
Installation Hardware Parts List.....	11	Program Input Display	
Section 2 - Signal Input.....	11 - 13	Frequency Display	
Input Switching		Section 11 - Tuning Voltage Regulator.....	39 - 41
Phono Pre-amp		Signal Display	
Tape Switching		Status Indicators	
Section 3 - Preamplifier.....	14 - 17	IR Sensor	
Volume		Section 12 - AM/FM Tuning Control.....	42 - 44
Equalizer		Section 13 - Output Processing and	
Loudness/Balance		Power Supply.....	45 - 47
Preamp Muting		Speaker Impedance Switching	
Section 4 - Power Amplifier.....	18 - 20	Speaker Switching	
Driver		Low Voltage Regulators	
Power Output		Section 14 - Back-up Power Supply.....	48
Power Guard		Power Relay	
Section 5 - AM Tuner.....	21 - 23	Alignment Procedure.....	49
Section 6 - FM Tuner.....	24 - 27	Repacking Instructions.....	50
Front End			
Multiplex			

Performance Specifications

AMPLIFIER SECTION

STEREO POWER OUTPUT

100 watts into 8 or 4 ohm loads is the minimum sine wave continuous average power output per channel, from 20 to 20,000Hz, with both channels operating.

POWER BANDWIDTH

20 to 20,000Hz

TOTAL HARMONIC DISTORTION

0.02% maximum at any power level from 250 milliwatts to rated power per channel, 20 to 20,000Hz, both channels operating.

INTERMODULATION DISTORTION

0.02% maximum at any power level from 250 milliwatts to rated power per channel, for any combination of frequencies from 20 to 20,000Hz, with both channels operating.

FREQUENCY RESPONSE

+0, -0.5dB from 20 to 20,000Hz at rated power.

INPUT SENSITIVITY

Phono 2.5mV produces rated output
Tape, Aux 250mV produces rated output
Power Amp 1.5V produces rated output

SIGNAL TO NOISE RATIO, A-WEIGHTED

Power Amp 100dB below rated output
Tape, Aux 90dB below rated output
Phono 80dB with 10mV input

MAXIMUM INPUT SIGNAL

Phono 90mV
High level 9V

INPUT IMPEDANCE

Phono 47k ohms, 47pF
Tape, Aux 30k ohms
Power Amp 22k ohm

DAMPING FACTOR

Greater than 40

TAPE OUTPUT

Phono 250mV with rated input
Tape 250mV with rated input
Tuner 0.8V at 100% modulation (FM)

PROGRAM EQUALIZER

±12dB at 30, 150, 500, 1500 and 10,000Hz

FM SECTION

USABLE SENSITIVITY

13dB which is 1.22uV across 75 ohms

50 dB QUIETING SENSITIVITY

Mono 17dB which is 2.0uV across 75 ohms
Stereo 37dB which is 20uV across 75 ohms

SIGNAL TO NOISE RATIO

Mono 75dB
Stereo 70dB

FREQUENCY RESPONSE

Mono +0, -1.0dB from 20 to 15kHz
Stereo +0, -1.0dB from 20 to 15kHz

HARMONIC DISTORTION

Mono 0.08% at 100Hz
0.08% at 1k
0.12% at 10k
Stereo 0.08% at 100Hz
0.08% at 1k
0.12% at 10k

INTERMODULATION DISTORTION

Mono 0.08%
Stereo 0.12%

CAPTURE RATIO

1.5dB

ALTERNATE CHANNEL SELECTIVITY

55dB

SPURIOUS RESPONSE

100dB

IMAGE RESPONSE

80dB

STEREO SEPARATION

45dB at 100Hz
50dB at 1k
35dB at 10k

SCA REJECTION

65dB

AM SECTION

SENSITIVITY

35uV (External Antenna)

SIGNAL TO NOISE RATIO

50dB at 30% modulation

60dB at 100% modulation

HARMONIC DISTORTION

0.5% maximum at 30% modulation,
0.2% typical

FREQUENCY RESPONSE

+0, -6dB, 20Hz to 4,000Hz

ADJACENT CHANNEL SELECTIVITY

40dB minimum, IHF

IMAGE REJECTION

65dB minimum

IF REJECTION

65dB minimum

GENERAL INFORMATION

SEMICONDUCTOR COMPLEMENT

118 Silicon Diodes

7 Varactor Diodes

41 Light Emitting Diodes

4 Seven Segment LED Display

96 Bipolar Transistors

45 Integrated Circuits

AC POWER OUTLETS

4 Black, switched, 1 Red, unswitched,
1000 watts, total

POWER REQUIREMENTS

120 volts, 50/60Hz, 60 to 480 watts

WEIGHT

34.5 pounds (15.6kg) net, 48.5 pounds
(22kg) in shipping carton

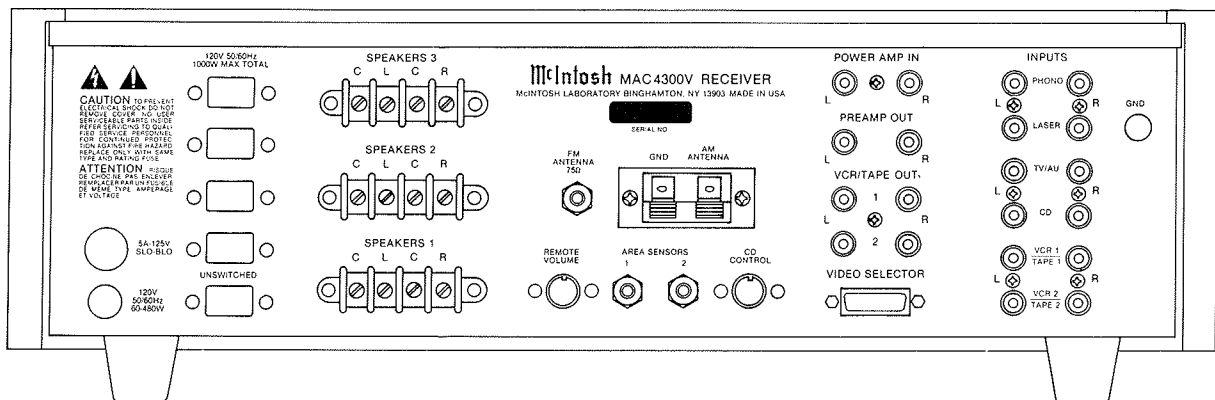
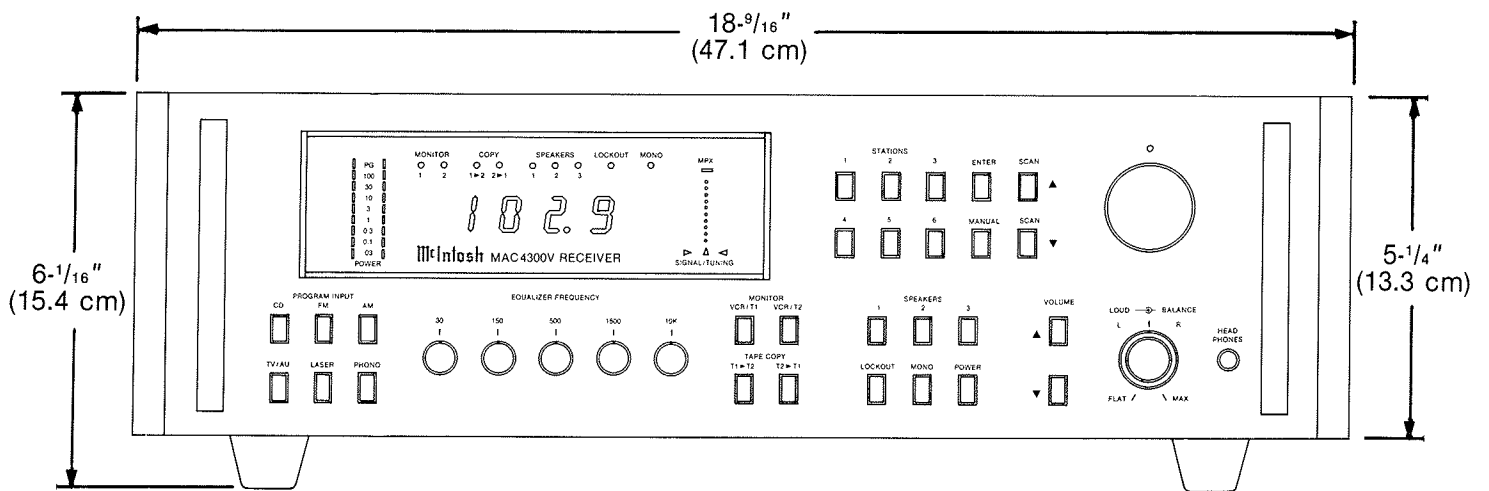
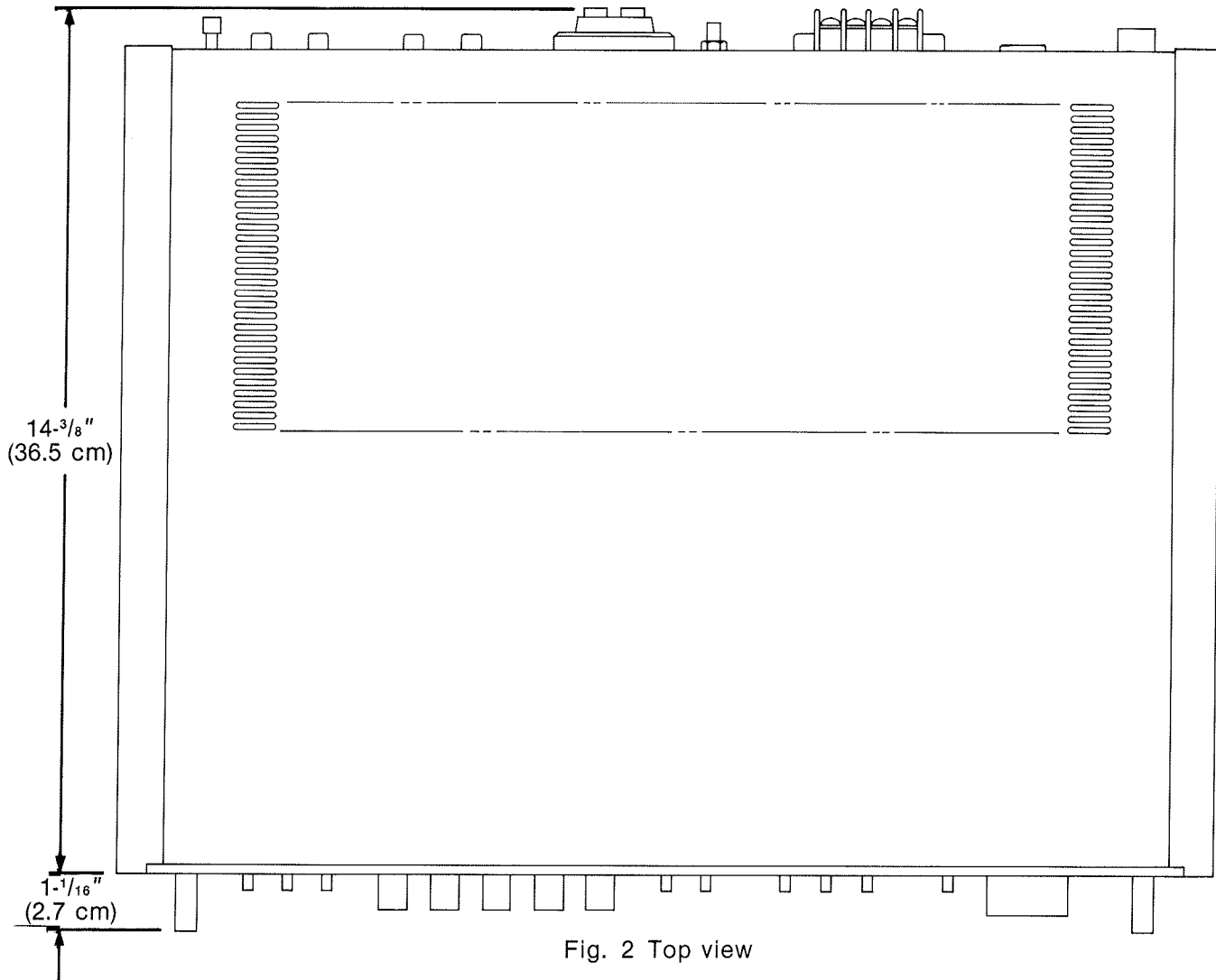

Fig. 1 Rear view

Mechanical Views



Notes

- Unless otherwise noted, all voltages indicated on the following schematics are measured under the following conditions:
 - AC input at 120 volts, 50/60Hz.
 - All voltages are $\pm 10\%$ with respect to ground. A high impedance (10 megohm) voltmeter must be used.
 - Front panel controls set at:

PROGRAM INPUT	Set to section under test
EQUALIZER FREQ (5)	Center detent
SPEAKERS 1	ON
POWER	ON
VOLUME	MAX
LOUD	FLAT (detent)
BALANCE	Center detent
TUNER	MANUAL
ALL OTHERS	OFF
 - The voltages enclosed in a box (Section 3 and 4) are signal voltages that are measured with a 0.25V, 1kHz signal connected to both channels of the CD inputs.
- The heavy lines on the schematics denote the primary signal paths.
 - Resistor values are in ohms.
 - Capacitor values smaller than 1 are microfarads (μF), and capacitor values greater than 1 are in picofarads (pF).
 - Inductor values are in microhenries (μH).

Block Diagrams

Tuner Section

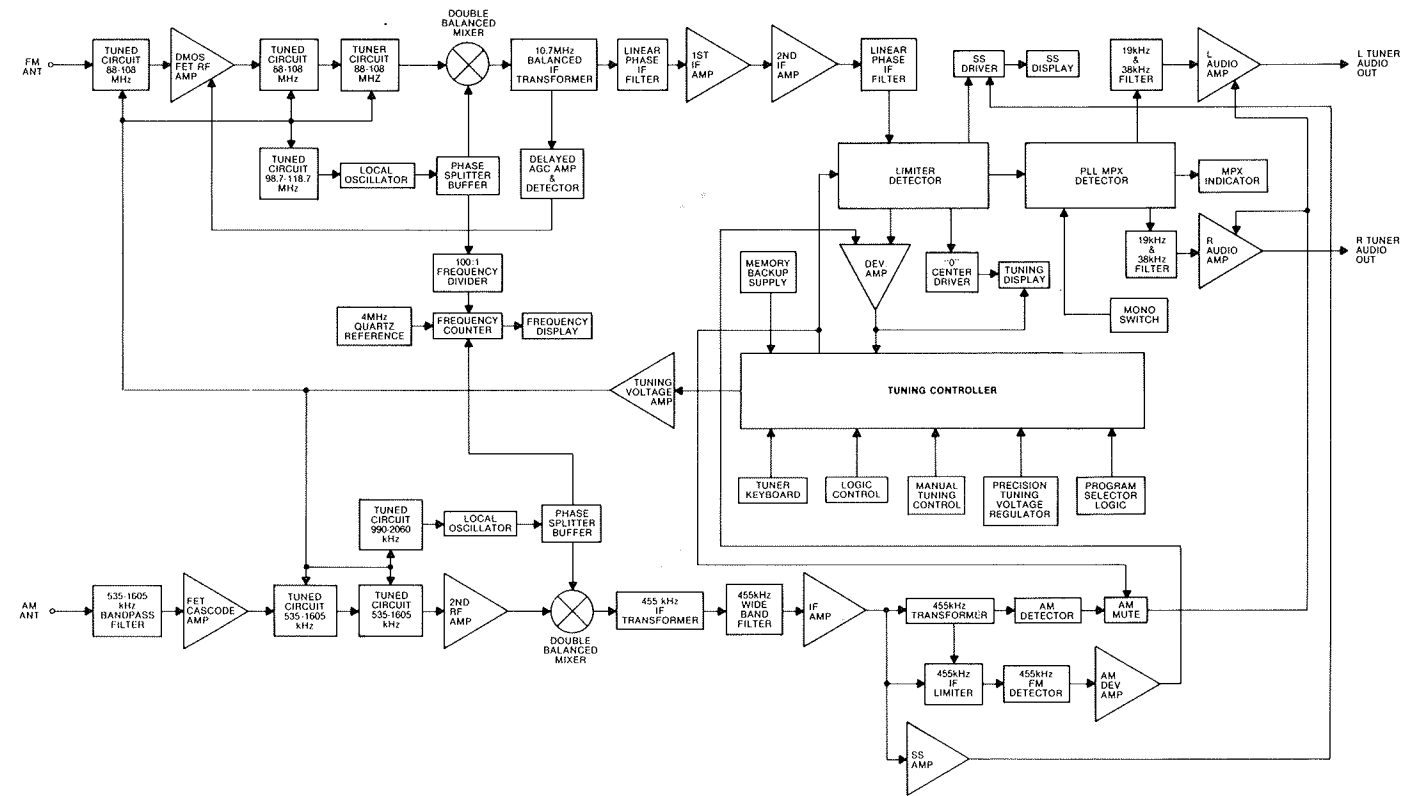

Preamp/Amplifier Section

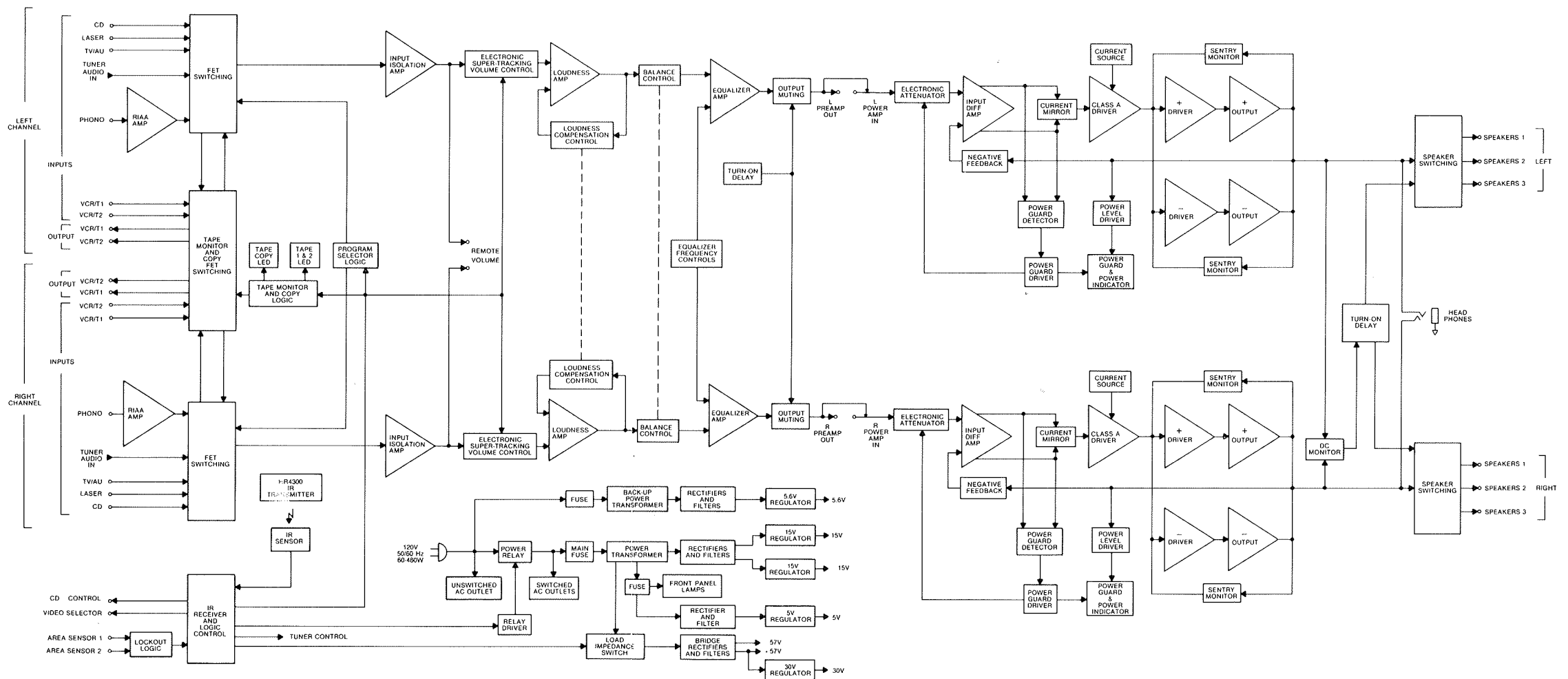

Section Locations

Fig. 4. Top view with cover removed.

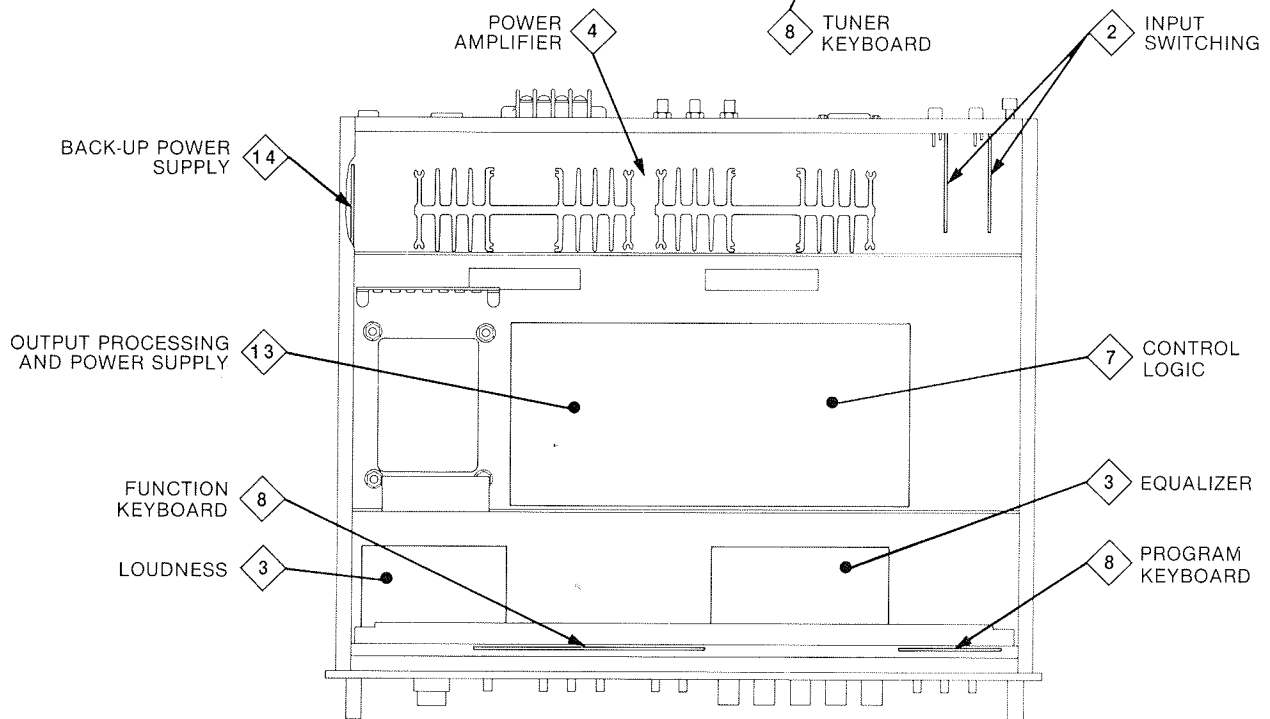
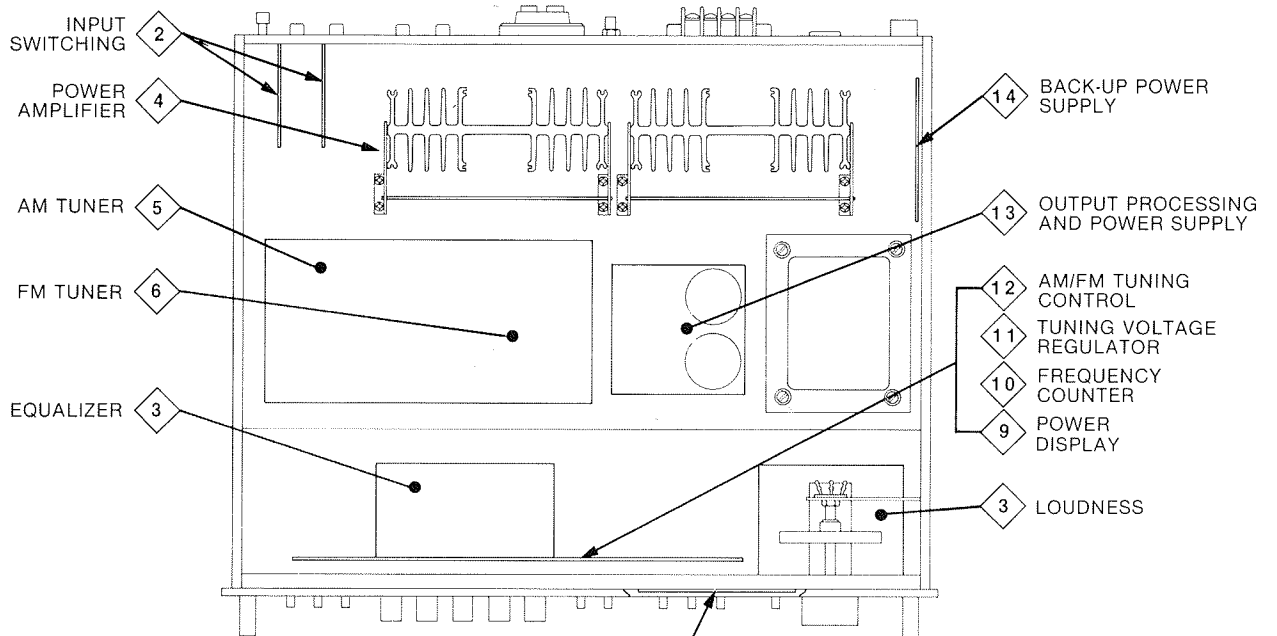
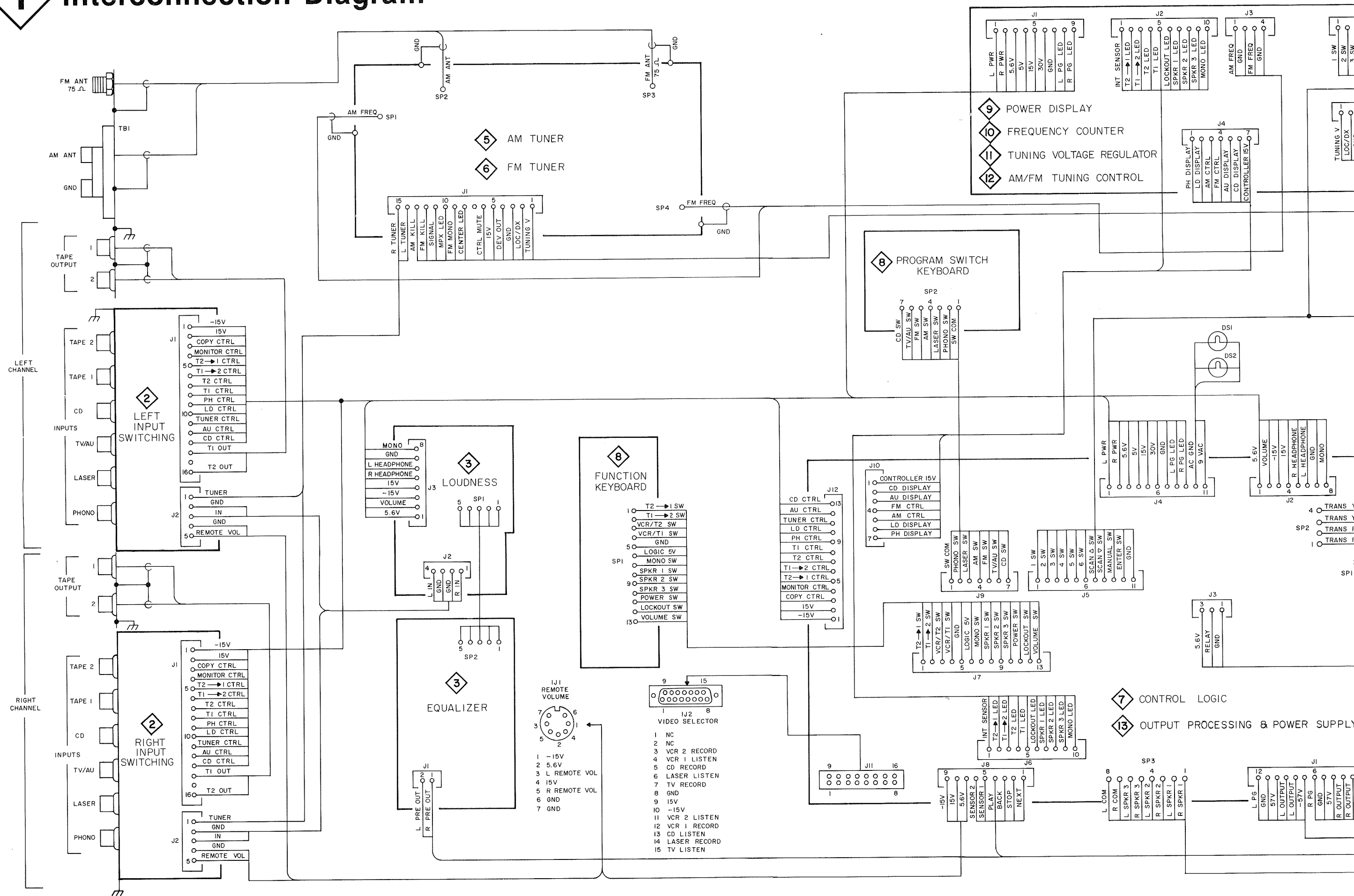
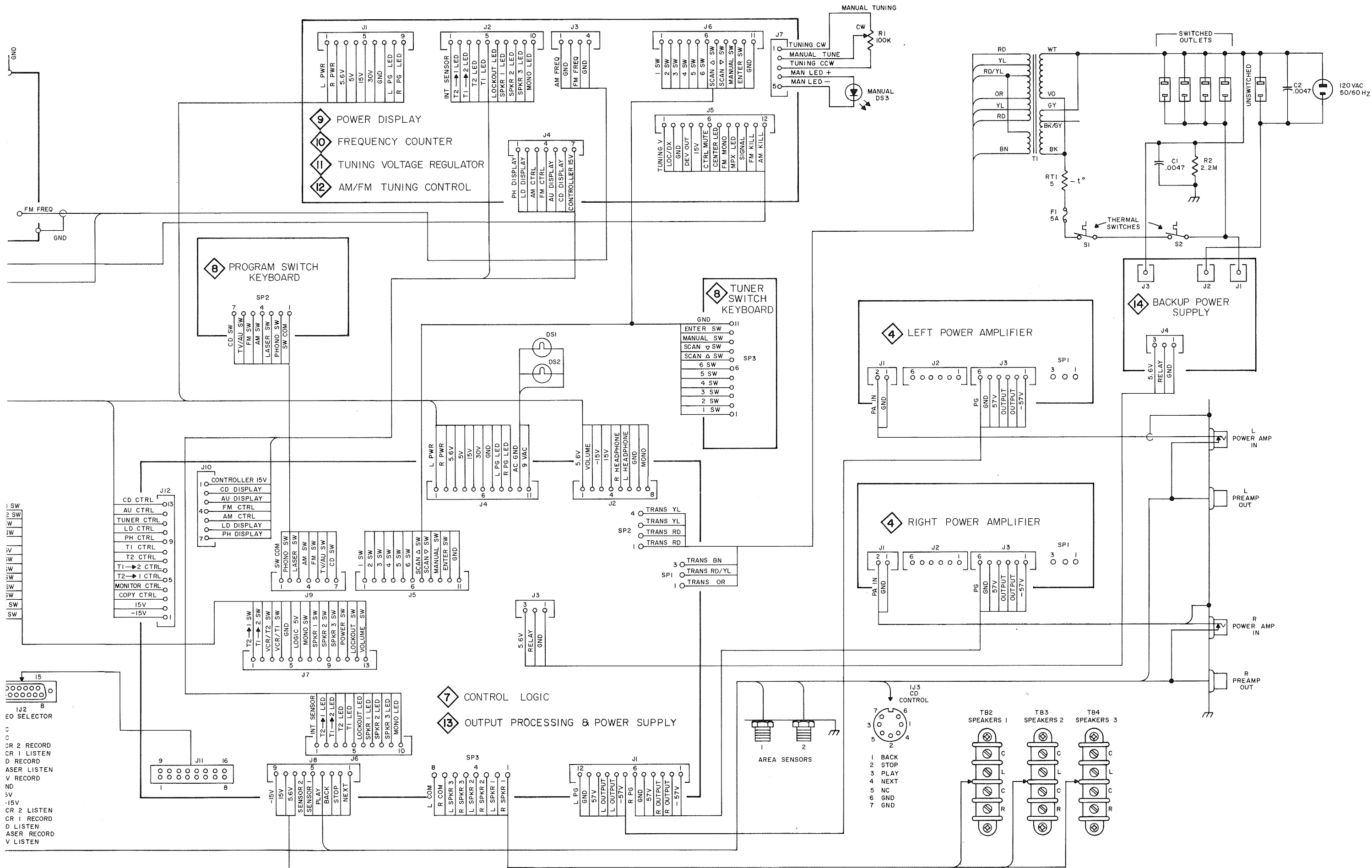

Fig. 5. Bottom view with cover removed.

1 Interconnection Diagram





**SECTION 1
PARTS LIST**



Symbol No.	Part No.	Description
CAPACITORS		
C1,C2	061276	CD, .0047uF, 400V, UL/CSA
LIGHTING DEVICES		
DS1,DS2	058101	INC, 12V, 150mA, Festoon
DS3	058078	LED, Red, SLP144B
FUSES		
F1	089007	Fuse, SB, 5A, 125V, MDL-5
	178122	Fuseholder
RESISTORS		
R1	134427	POT, Tuning
THERMISTORS		
RT1	144151	Thermister, 5 ohm
SWITCHES		
S1,S2	153017	Thermal Switch
TRANSFORMERS		
T1	159200	Power Transformer

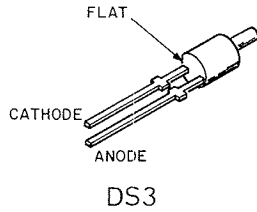

**FRONT PANEL AND TRIM
PARTS LIST**

Symbol No.	Part No.	Description
	104017	Felt Washer, Knob
	046812	Glass, Display
	046826	Front Panel
	018228	Handle, Front Panel
	090207	Knob, Balance
	090218	Knob, Loudness
	090221	Knob, Equalizer (5)
	100119	Machine Screw, #10 x 7/8, Philips (For wood Sides)
	017246	Pushbutton, Black
	017268	Pushbutton, Red
	046809	Tuning Knob
	030196	Wood Side, Left, Secure W/100119 Screws
	030195	Wood Side, Right Secure W/100119 Screws

**INSTALLATION HARDWARE
PARTS LIST**

Symbol No.	Part No.	Description
	170174	Cable, 7 Pin Din
	170148	FM Dipole Antenna
	046823	Hardware Package
	017218	Plastic Feet, Secure W/100159 Screws
	101016	Screw, #10 x 1-1/4, Slotted (To secure unit to a 1/2" shelf)
	101017	Screw, #10 x 1-1/2, Slotted (To secure unit to a 3/4" shelf)
	100159	Screw, #10 x 3/4, Phillips (For Plastic Feet)
	104033	Washer, #10, Flat (For use with 101016 or 101017 Screw)

Signal Input

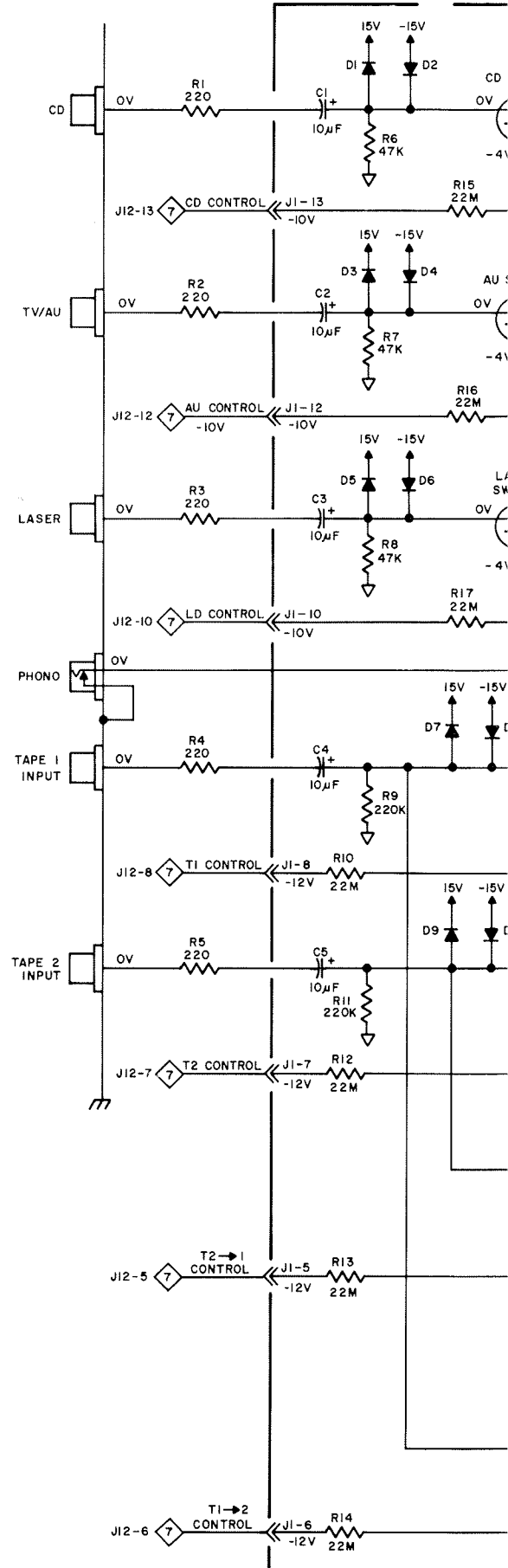

Signal Input

2

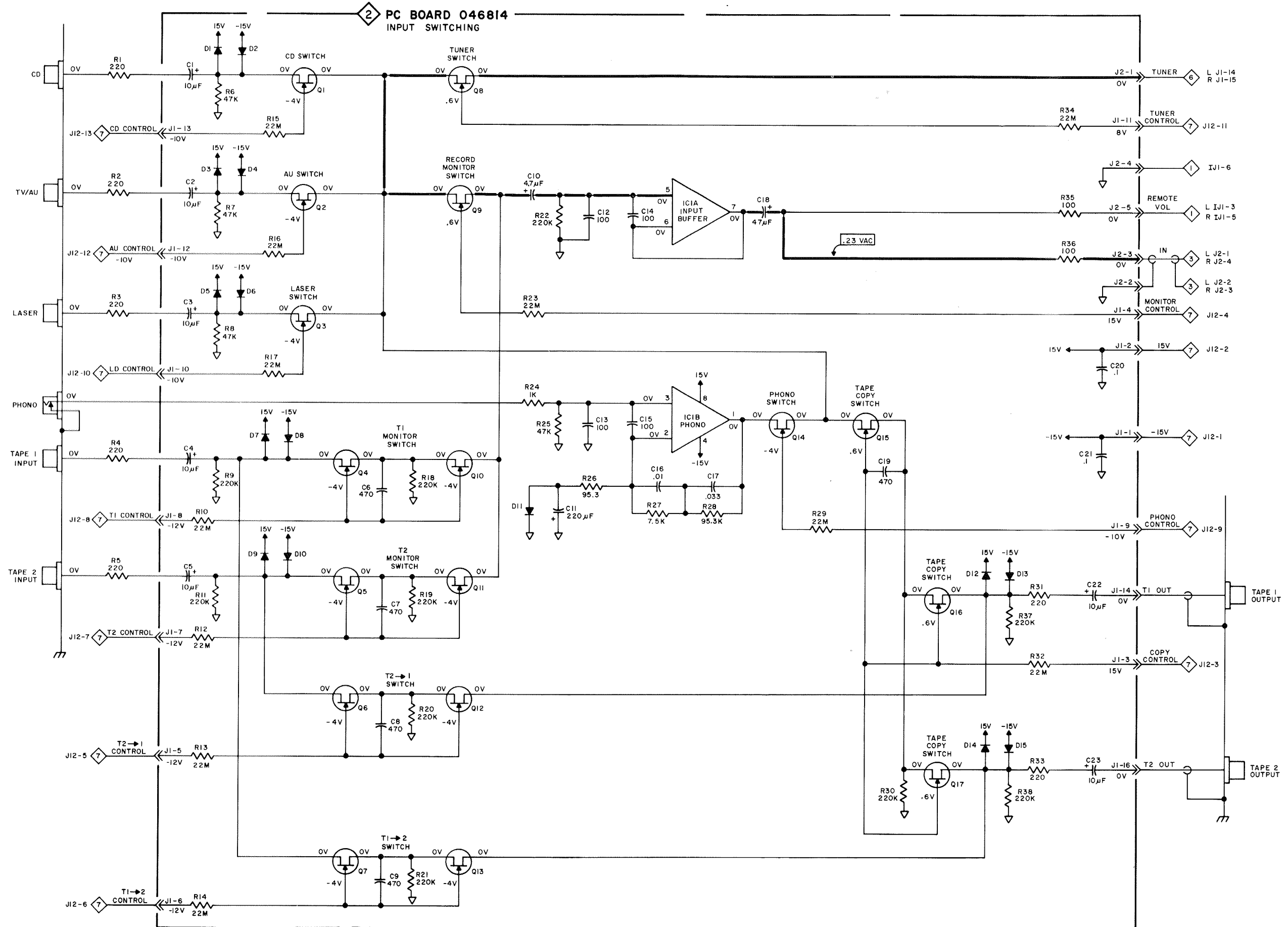

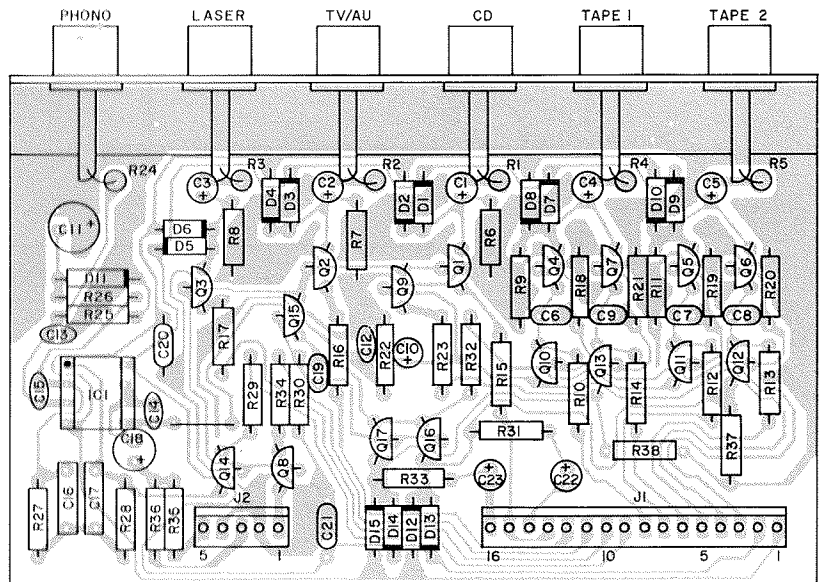
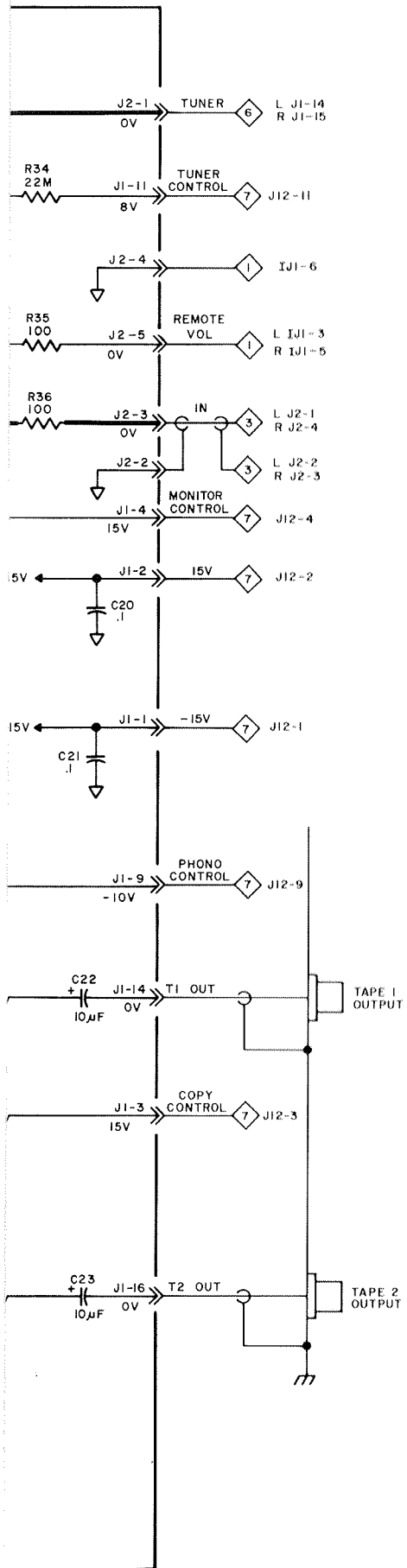

INPUT SWITCHING PCB 046814

SECTION 2
PARTS LIST

Symbol No.	Part No.	Description
------------	----------	-------------

DIODES

D1-D10	070047	SIG, 75V, 150mA, 1N4148
D11	070003	Ge, SIG, 45V, 10mA, 1N541
D12-D15	070047	SIG, 75V, 150mA, 1N4148

INTEGRATED CIRCUITS

IC1	133094	Dual Operational Amp, NE5532N
-----	--------	-------------------------------

TRANSISTORS

Q1-Q17	132193	N, JFET, 2N4392
--------	--------	-----------------

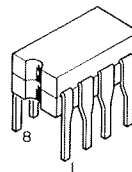

IC1

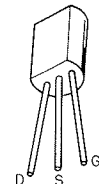

Q1-Q17

3 Preamp

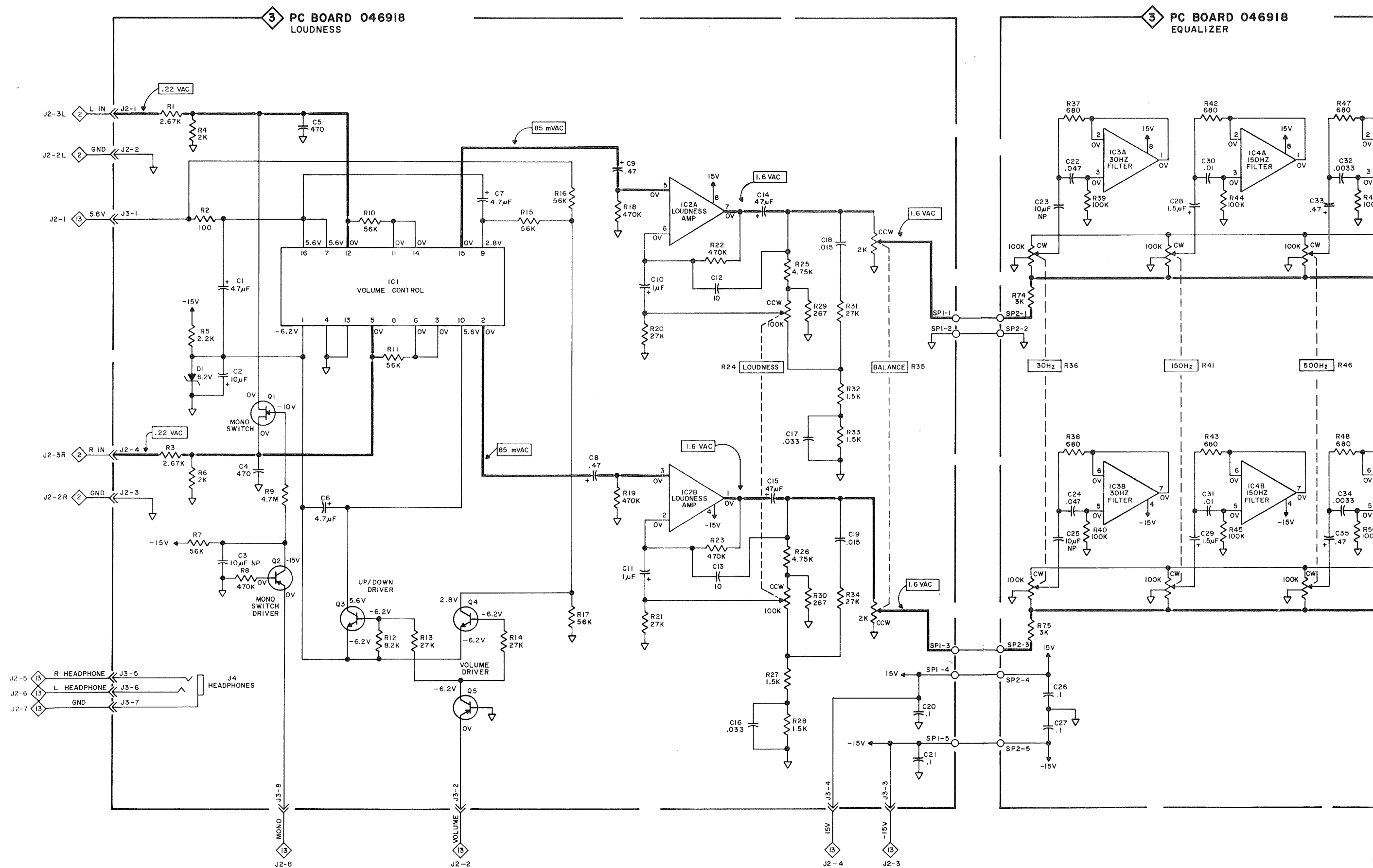

3 PC BOARD 046918
EQUALIZER

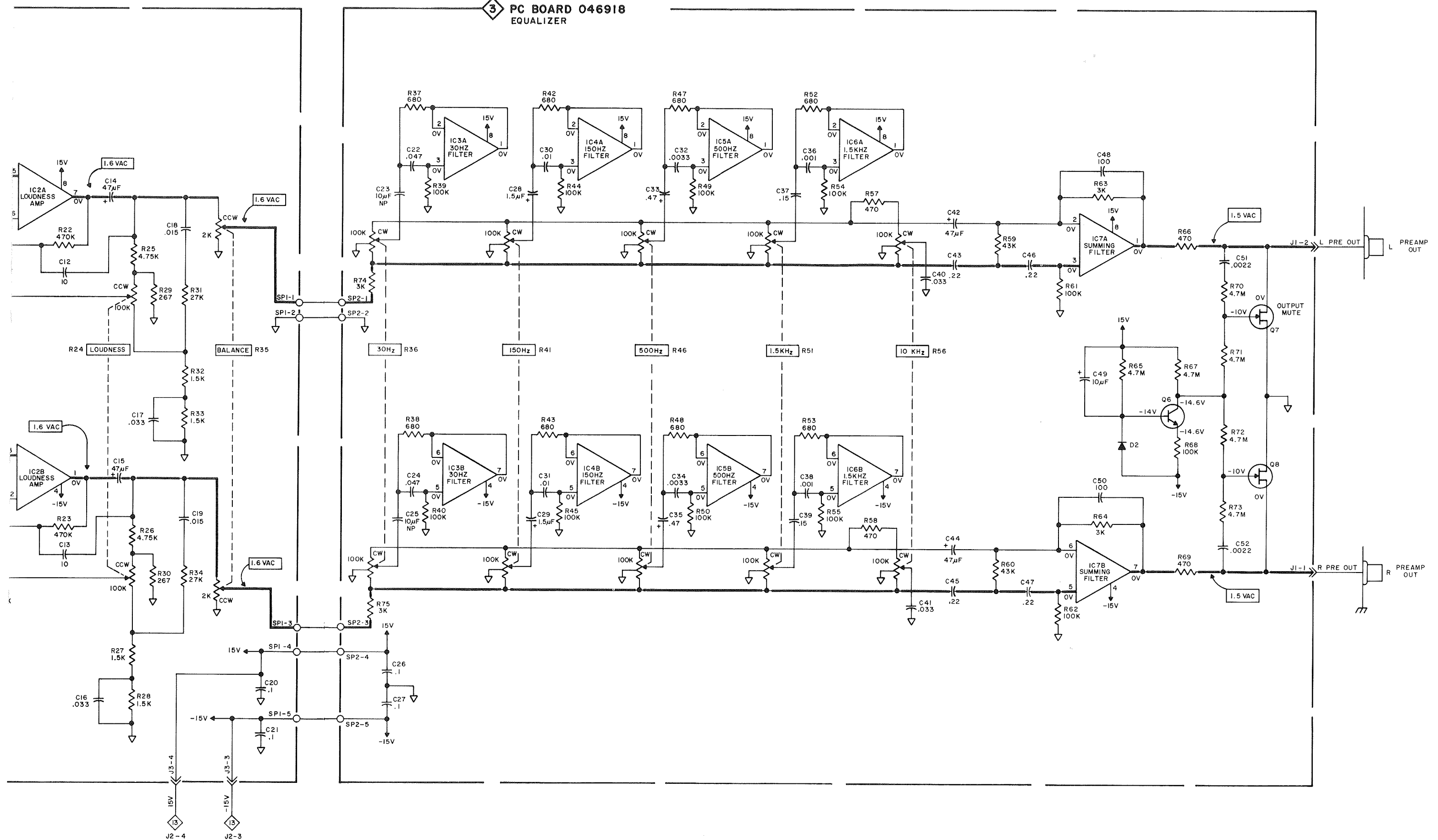

Preamplifier

3

SECTION 3 PARTS LIST

Symbol No.	Part No.	Description
DIODES		
D1	070085	ZN, 6.2V, 5%, 500mW, 1N5234B
D2	070047	SIG, 75V, 150mA, 1N4148
INTEGRATED CIRCUITS		
IC1	133132	CMOS, Volume Control, TC9153P
IC2	133094	Dual Operational Amp, NE5532N
IC3-IC6	133028	Dual Hi-Speed Operational Amp, MC4558CP1
IC7	133094	Dual Operational Amp, NE5532N
TRANSISTORS		
Q1	132193	N, JFET, 2N4392
Q2, Q5	132223	PNP, MPS4126
Q3, Q4	132223	NPN, MPS4124
Q6	132223	NPN, MPS4124
Q7, Q8	132222	N, FET, J108
RESISTORS		
R24, R35	134397	POT, Balance/Loudness
R36, R41	134316	POT, 100K ohm/100K ohm, Equalizer
R46, R51	134316	POT, 100K ohm/100K ohm, Equalizer
R56	134316	POT, 100K ohm/100K ohm, Equalizer
MISCELLANEOUS		
J4	117340	Headphone Jack

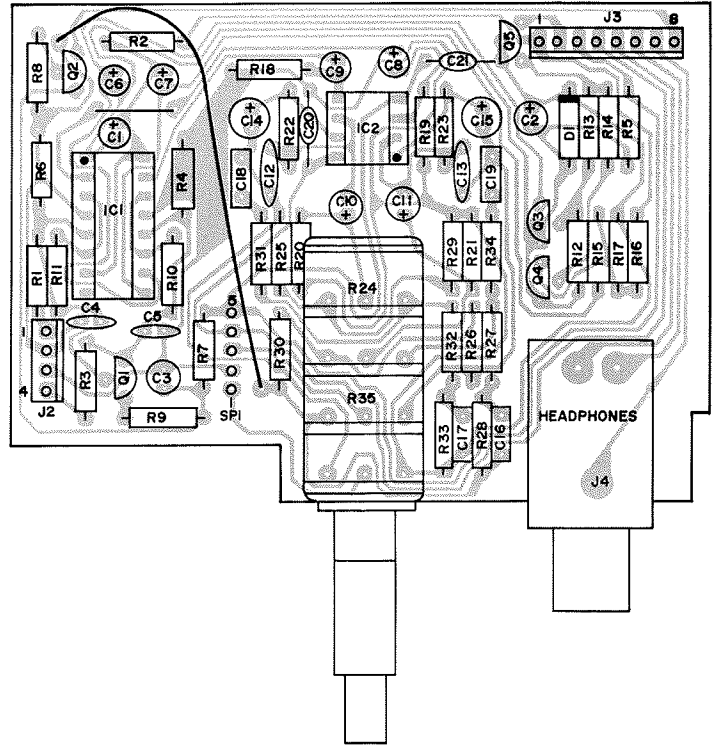

LOUDNESS PCB 046918 A

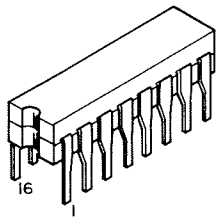

IC1

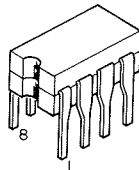

IC2-IC7



Q1, Q7, Q8

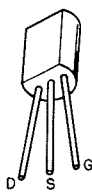

Q2-Q6

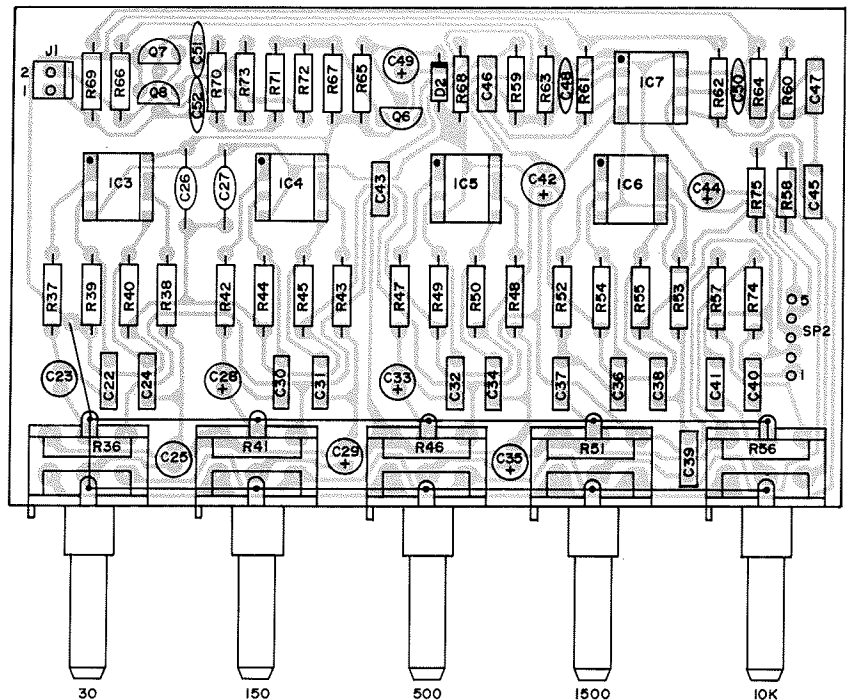

EQUALIZER PCB 046918 B

4

Power Amplifier

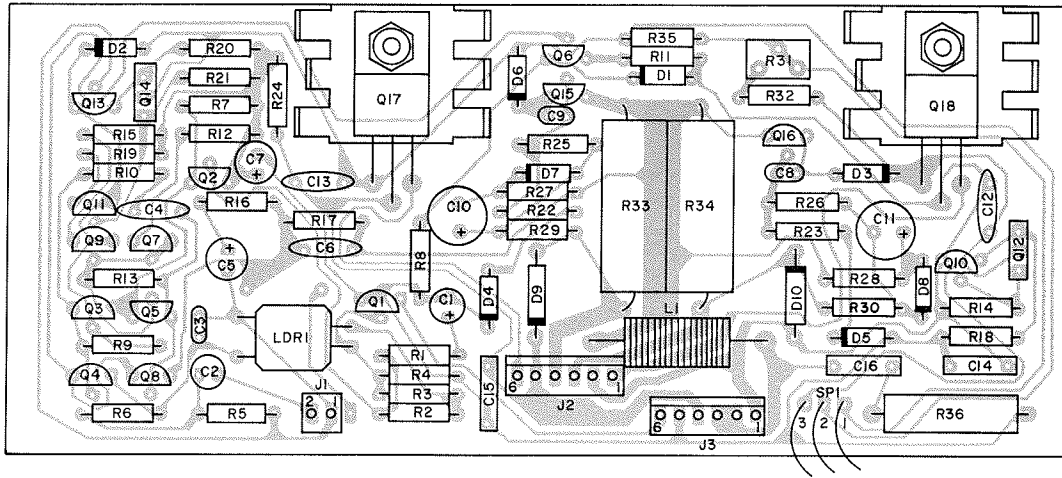

POWER AMPLIFIER PCB 046802 A

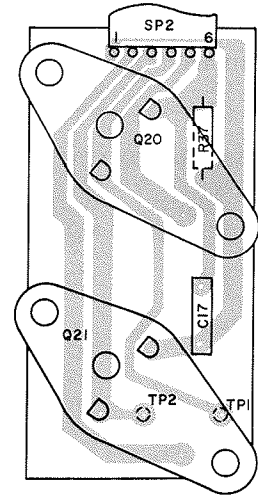

PCB 046802 B

SECTION 4 PARTS LIST

Symbol No.	Part No.	Description
------------	----------	-------------

DIODES

D1	070085	ZN, 6.2V, 5%, 500mW, 1N5234B
D2	070098	SIG, 175V, 500mW, FDH400
D3-D8	070047	SIG, 75V, 150mA, 1N4148
D9, D10	070131	RECT, 400V, 1A, 1N4004

LIGHT DEPENDENT RESISTORS

LDR1	144179	LDR, VTL5C9
------	--------	-------------

TRANSISTORS

Q1, Q3	132223	NPN, MPS4124
Q2	132236	PNP, 2SA970-BL
Q4, Q6	132235	NPN, 2SC2240-BL
Q5	132223	NPN, MPS4124
Q7, Q9	132224	PNP, MPS4126
Q8	132235	NPN, 2SC2240-BL
Q10	132223	NPN, MPS4124
Q11	132224	PNP, MPS4126
Q12	132233	NPN, 2SC3423
Q13	132236	PNP, 2SA970-BL
Q14	132234	PNP, 2SA1360
Q15	132223	NPN, MPS4124
Q16	132224	PNP, MPS4126
Q17	132231	NPN, 2SC3298B-0
Q18	132232	PNP, 2SA1306B-0
Q19	132233	NPN, 2SC3423
Q20	132189	PNP
Q21	132188	NPN



Q1, Q3, Q5, Q7
Q9-Q11, Q15, Q16

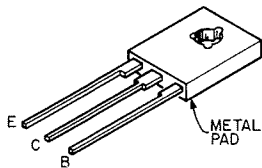

Q12, Q14, Q19



Q2, Q4, Q6
Q8, Q13

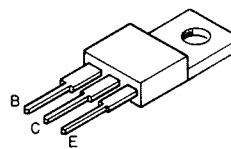

Q17, Q18

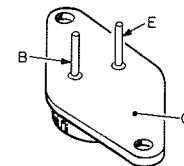

Q20, Q21

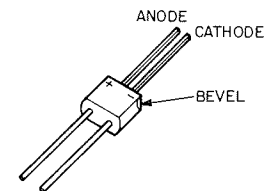

LDR1

Power Amplifier 4

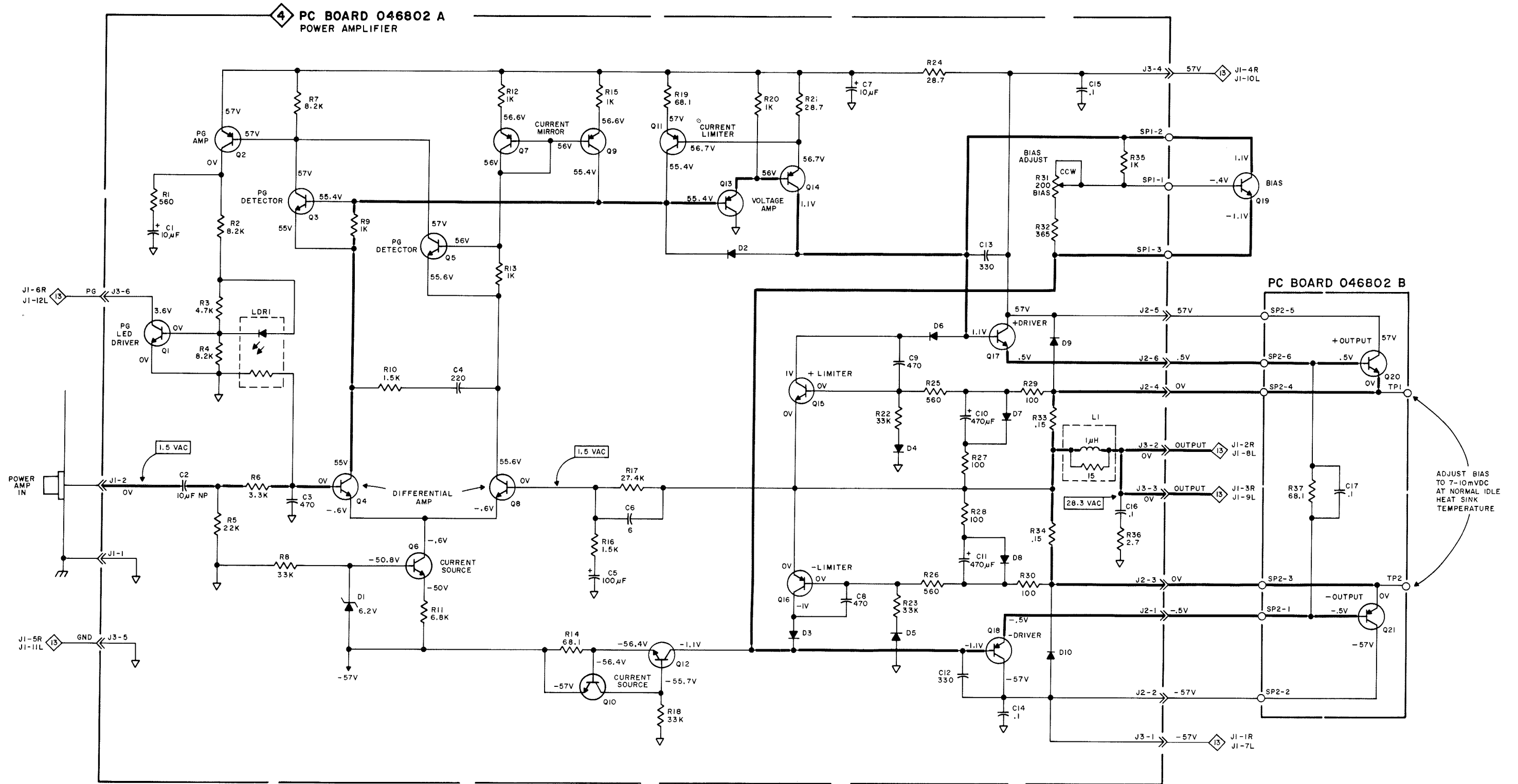

5 AM Tuner

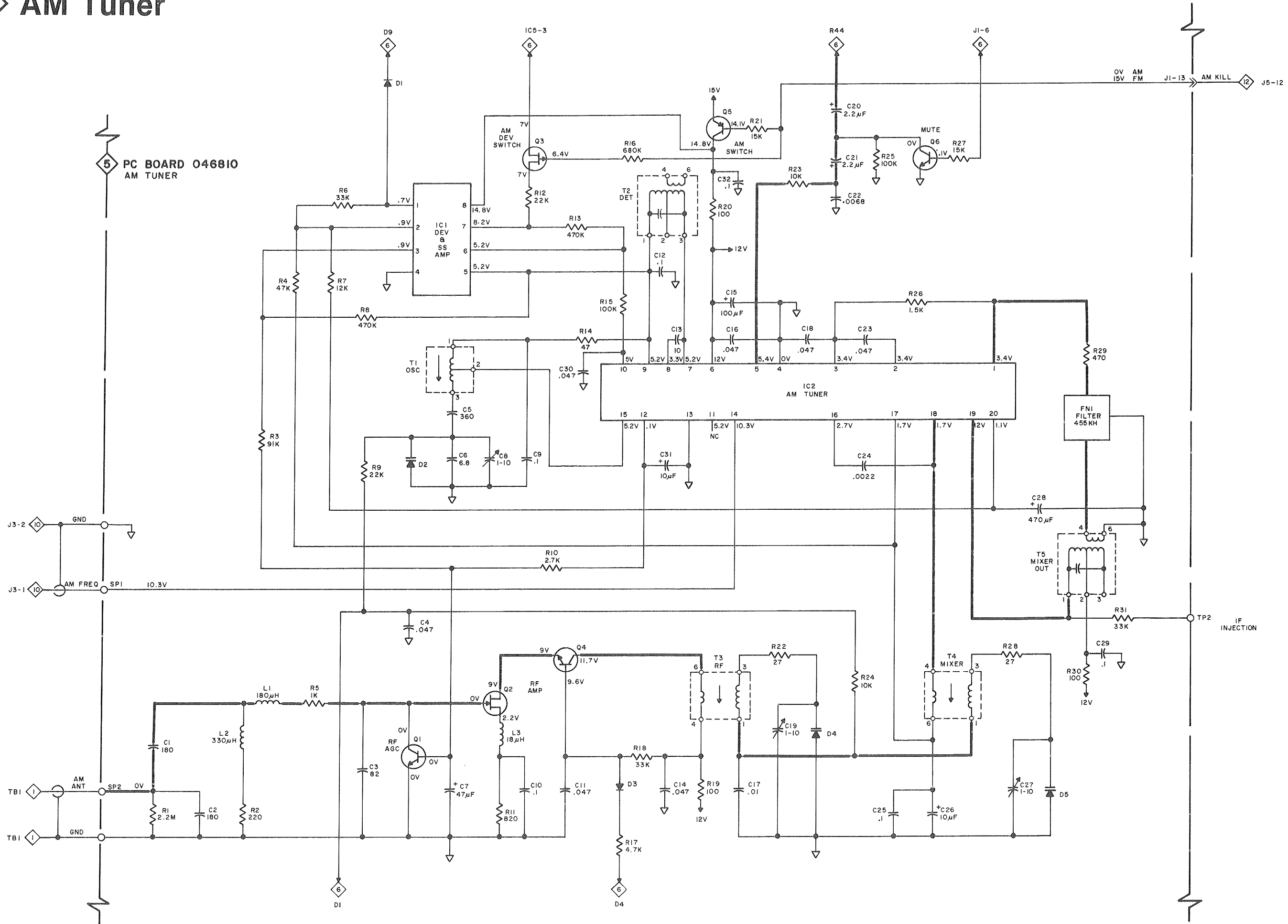

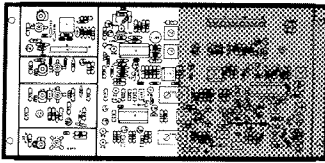

AM TUNER
PORTION OF
PCB 046811

(Only Section 5 Parts Symbol Numbered)

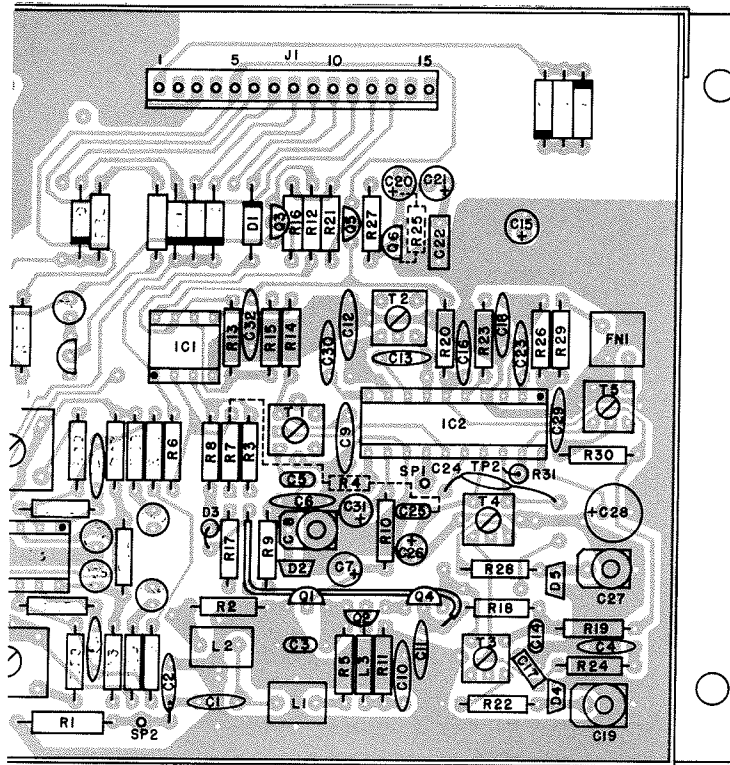

AM/FM TUNER PCB 046811

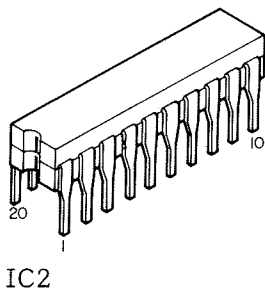
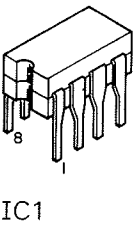
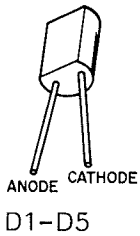

**SECTION 5
PARTS LIST**

Symbol No.	Part No.	Description
------------	----------	-------------

CAPACITORS

C8, C19	060027	Trimmer, 2-10pF
C27	060027	Trimmer, 2-10pF

DIODES

D1, D3	070047	SIG, 75V, 150mA, 1N4148
D2, D4	070125	VAC, AM, SVC333
D5	070125	VAC, AM, SVC333

FILTERS

FN1	180035	Filter, CER, 455kHz
-----	--------	---------------------

INTEGRATED CIRCUITS

IC1	133105	Dual Hi-Speed Operational Amp MC3458P1
IC2	133145	AM Tuner, MC13041P

TRANSISTORS

Q1	132223	NPN, MPS4124
Q2	132193	N, JFET, 2N4392
Q3	132220	P, FET, J176
Q4, Q6	132223	NPN, MPS4124
Q5	132224	PNP, MPS4126

TRANSFORMERS

T1	162115	AM Oscillator
T2	162113	AM-IF Matching
T3	162117	AM-RF (Primary)
T4	162116	AM-RF (Secondary)
T5	162113	AM-IF Matching



6

FM Tuner

FM TUNER
PORTION OF
PCB 046811



(Only Section 6 Parts Symbol Numbered)

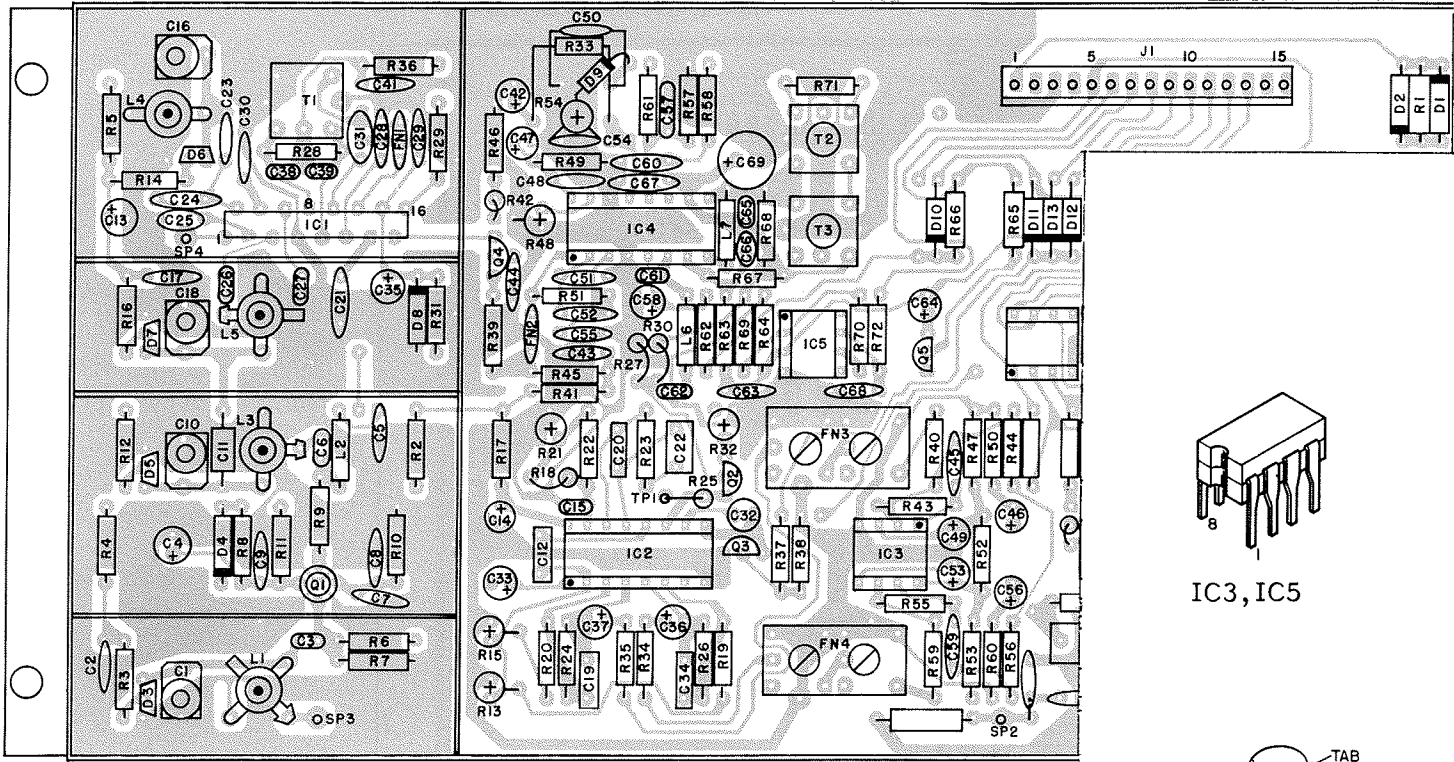

AM/FM TUNER PCB 046811

**SECTION 6
PARTS LIST**

Symbol No.	Part No.	Description
DIODES		
D1,D2	070003	Ge, SIG, 45V, 10mA, 1N541
D3	070122	VAC, Matched, Selected SVC211
D4	070047	SIG, 75V, 150mA, 1N4148
D5-D7	070122	VAC Matched Selected SVC211
D8	070130	ZN, 8.2V, 5%, 500mW, 1N5237
D9,D13	070047	SIG, 75V, 150mA, 1N4148
FILTERS		
FN1, FN2	180024	Filter, CER, 10.64-10.76MHz, Color Coded, SFE10.7
FN3, FN4	180028	Filter, LC, Low Pass, Multiplex
INTEGRATED CIRCUITS		
IC1	133129	RF Mixer, IF, LA1170
IC2	133056	MPX-PLL Demodulator, TCA4500A
IC3	133028	Dual Hi-Speed Operational Amp, M4558CP1
IC4	133110	FM-IF System, LA1235
IC5	133131	Operational Amp, MC34081P
TRANSISTORS		
Q1	132205	N, MOSFET Dual Gate, MFE521
Q2,Q3	132223	NPN, MC4124
Q4	132181	NPN, MPSH10
Q5	132224	PNP, MC4126
TRANSFORMERS		
T1	162114	FM Mixer
T2	162103	FM Discriminator (Secondary)
T3	162102	FM Discriminator (Primary)

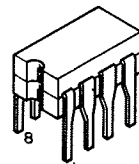

IC3, IC5

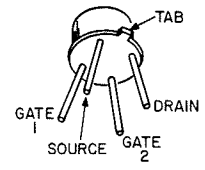

Q1

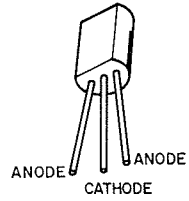

D3, D5-7

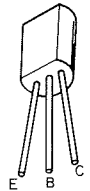

Q2, Q3, Q5

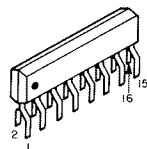

IC1

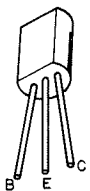

Q4

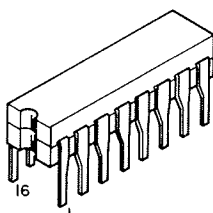

IC2, IC4

FM Tuner 6

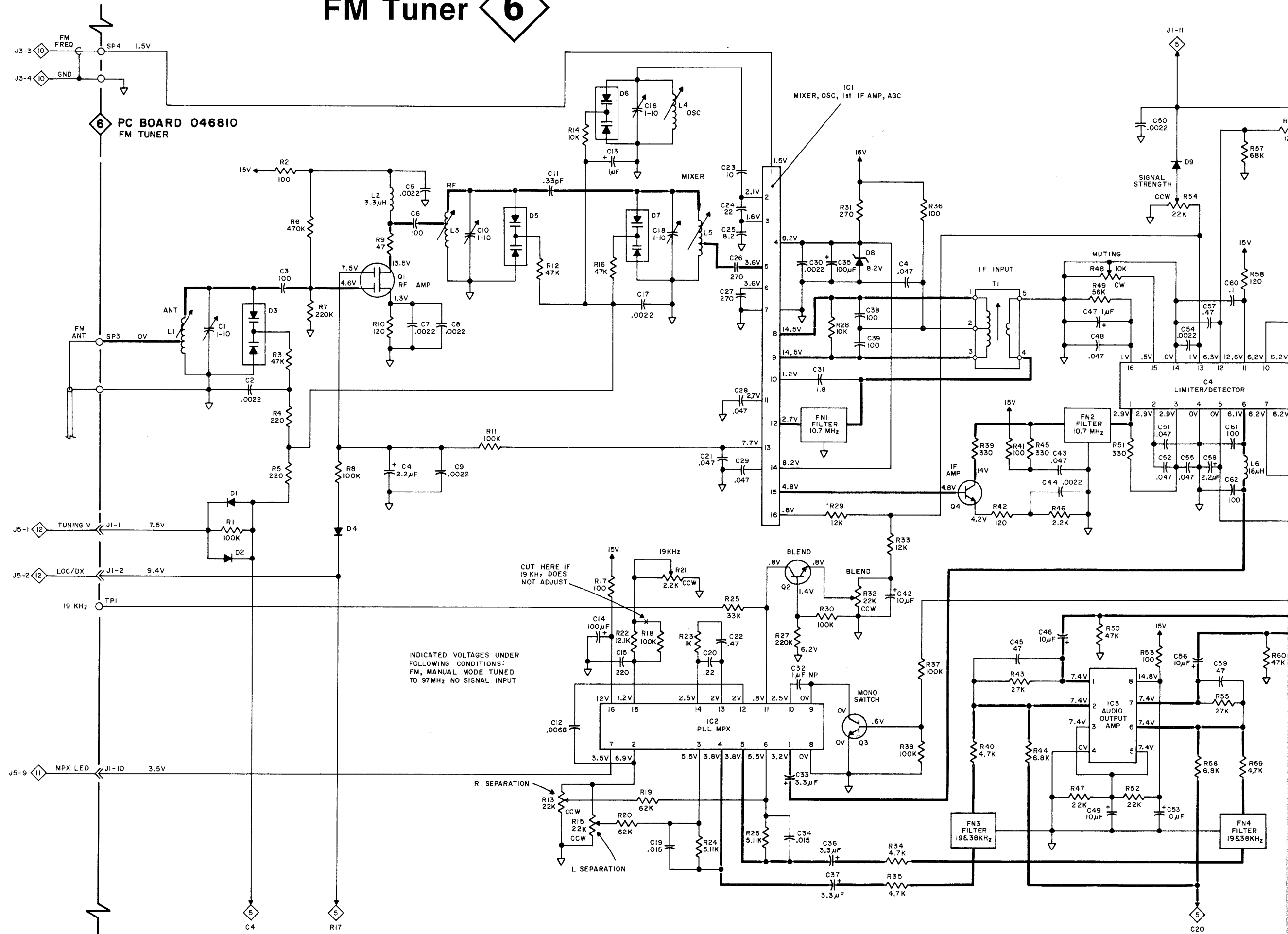

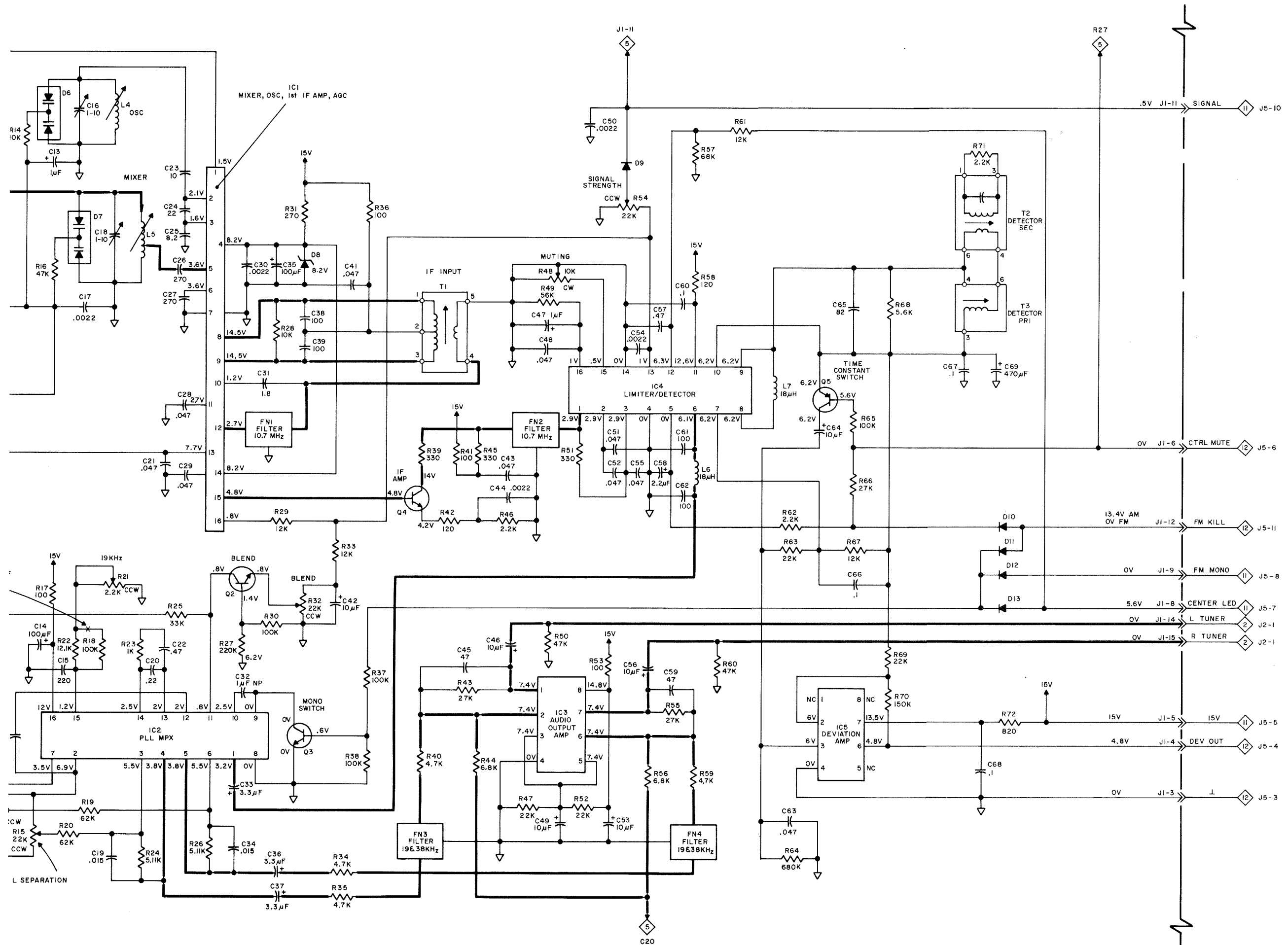

7 Control Logic

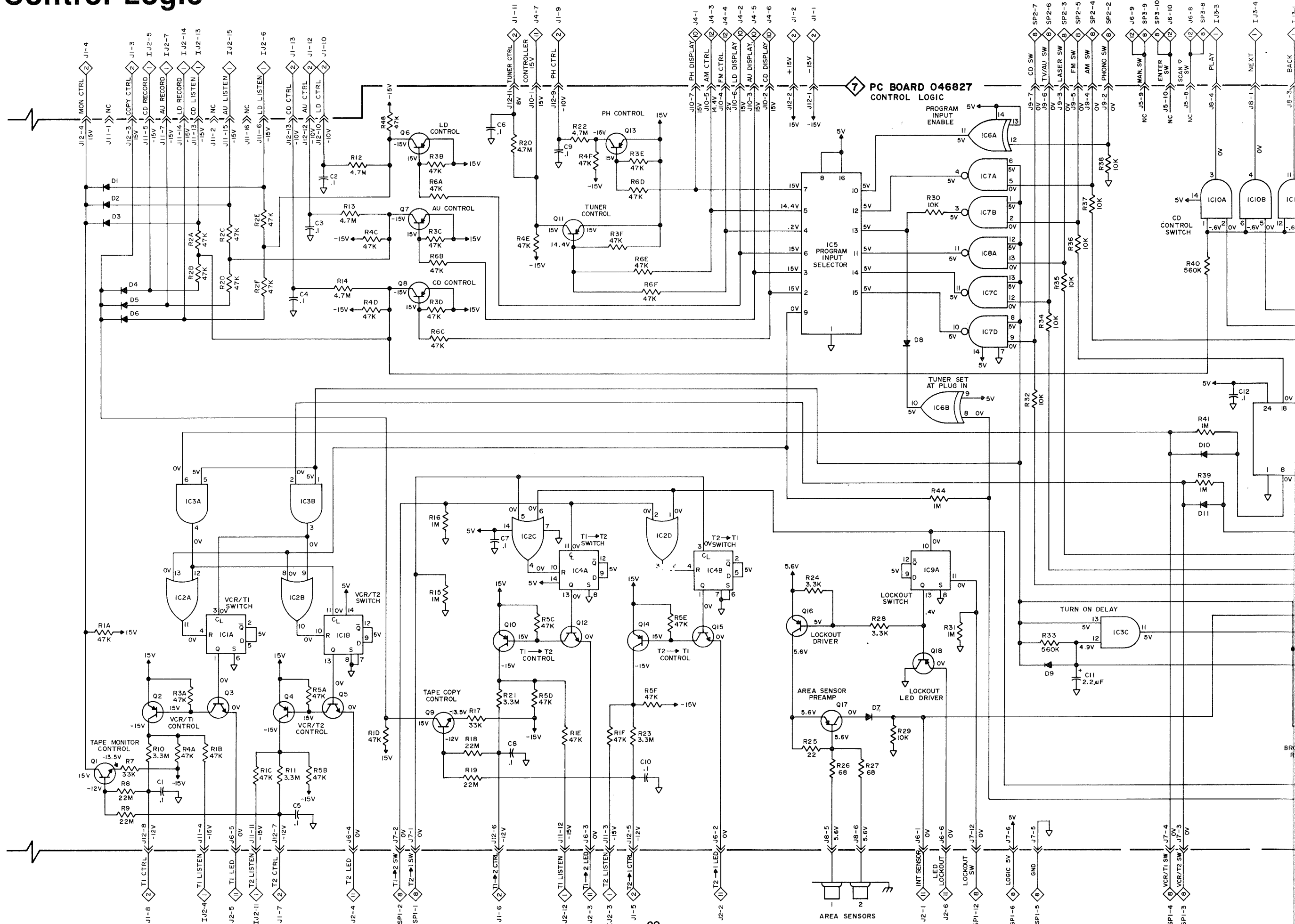

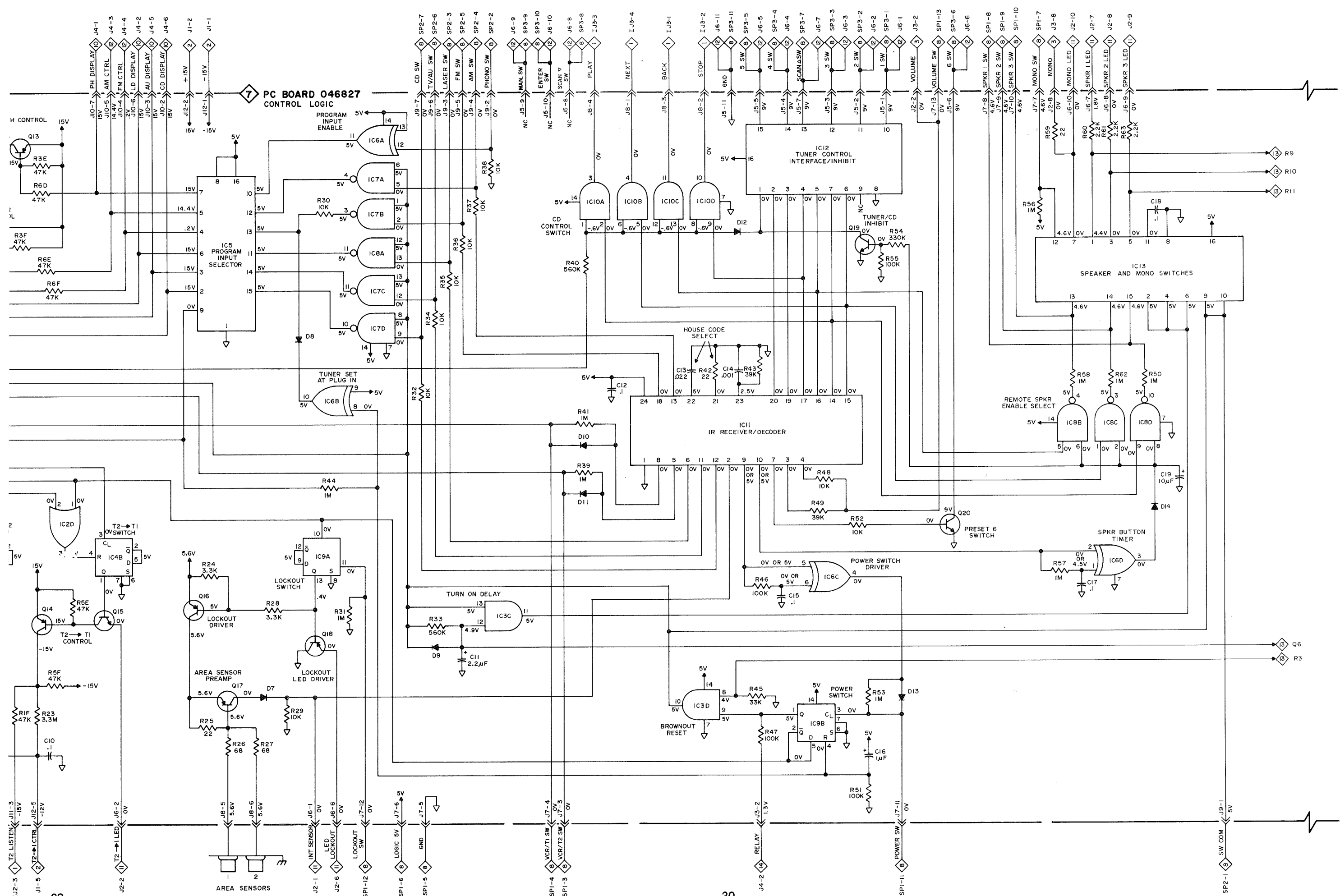

Control Logic

7

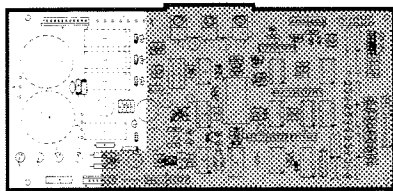

CONTROL LOGIC
PORTION OF
PCB 046827

(Only Section 7 Parts Symbol Numbered)

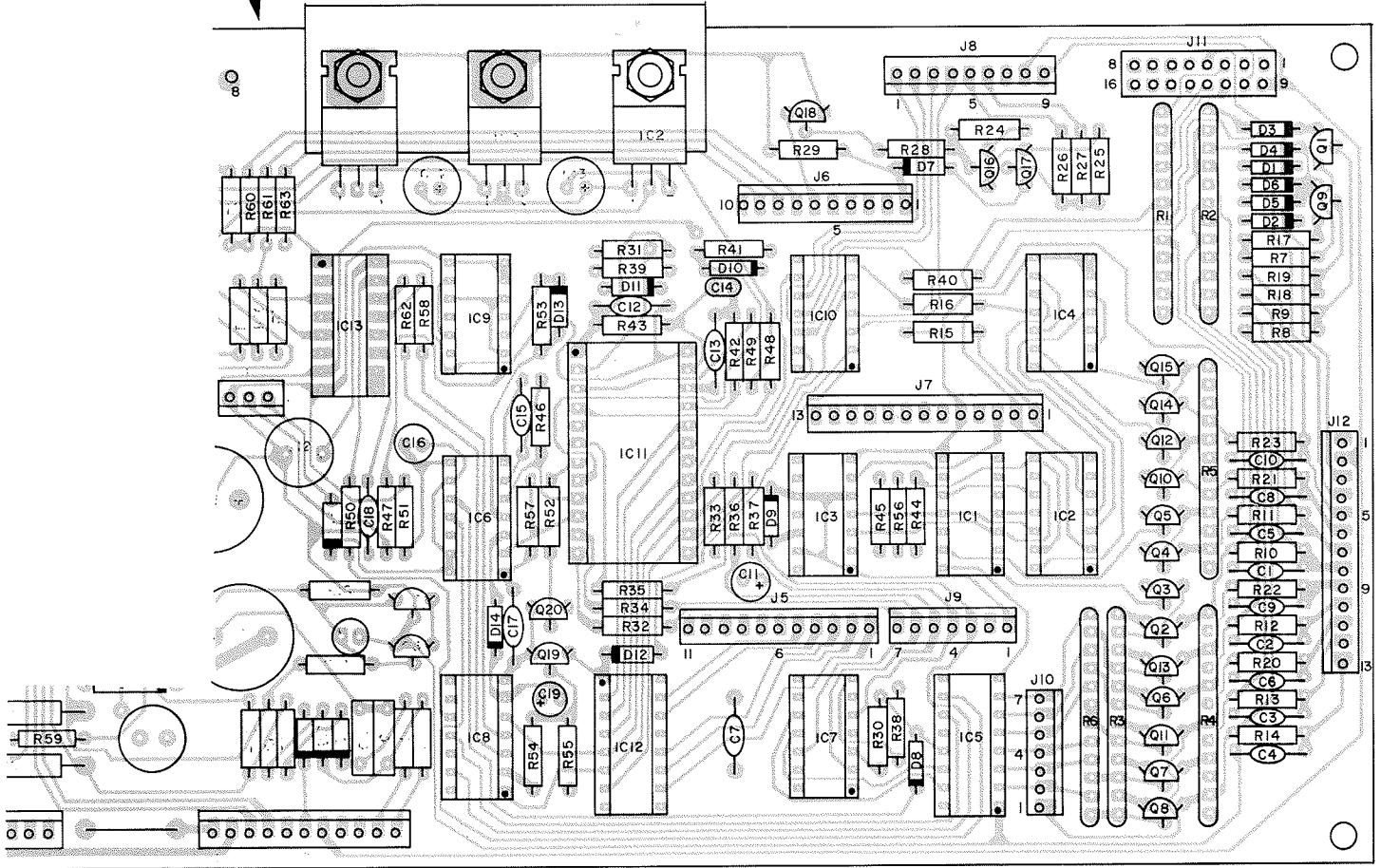

POWER SUPPLY/LOGIC PCB 046827

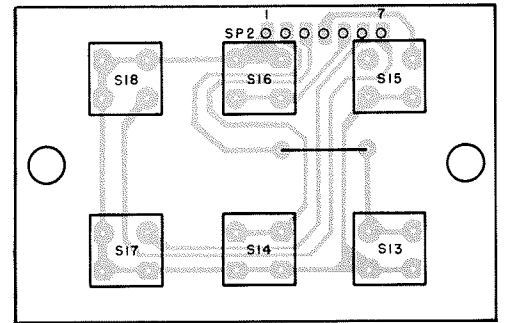
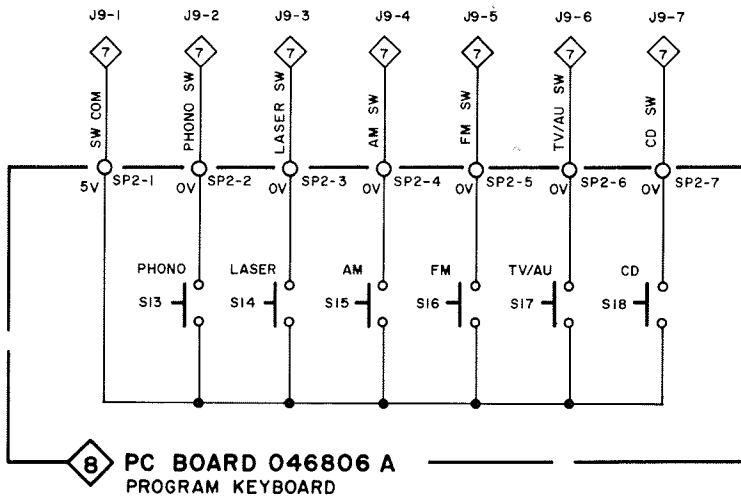

PROGRAM KEYBOARD PCB 046806 A

**SECTION 7
PARTS LIST**

Symbol No.	Part No.	Description
DIODES		
D1-D14	070047	SIG, 75V, 150mA, 1N4148
INTEGRATED CIRCUITS		
IC1	133053	CMOS, Dual Type-D F-F, MC14013AL
IC2	133073	CMOS, Quad 2-Input OR Gate, MC14071B

IC3	133076	CMOS, Quad 2-Input AND Gate, MC14081B
IC4	133053	CMOS, Dual Type-D F-F, MC14013AL
IC5	133143	6-Channel Switch, TC9135P
IC6	133136	Quad 2-Input Exclusive OR Gate, HEF4070BPN
IC7,IC8	133063	CMOS, Quad 2-Input NAND Gate, MC14011B
IC9	133053	CMOS, Dual Type-D F-F, MC14013AL

IC10	133076	CMOS, Quad 2-Input AND Gate, MC14081B
IC11	133133	CMOS, Remote Control Receiver TC9150P
IC12	133137	6-Input Strobed Driver, LB1760
IC13	133142	Quad Cyclic Switch, TC9130P
TRANSISTORS		
Q1	132090	NPN, DAR, Selected MPSA14
Q2,Q4	132056	PNP, 2N5087

Q3,Q5	132223	NPN, MPS4124
Q6-Q8	132056	PNP, 2N5087
Q9	132090	NPN, DAR, Selected MPSA14
Q10,Q11	132056	PNP, 2N5087
Q12	132223	NPN, MPS4124
Q13,Q14	132056	PNP, 2M5087
Q15	132223	NPN, MPS4124
Q16-Q18	132224	PNP, MPS4126
Q19,Q20	132223	NPN, MPS4124

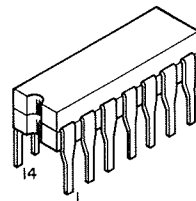

IC1-IC4,
IC6-IC10

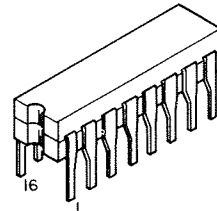

IC5, IC12, IC13

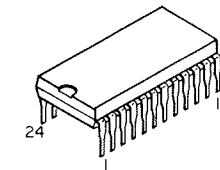

IC11



Q1-Q20

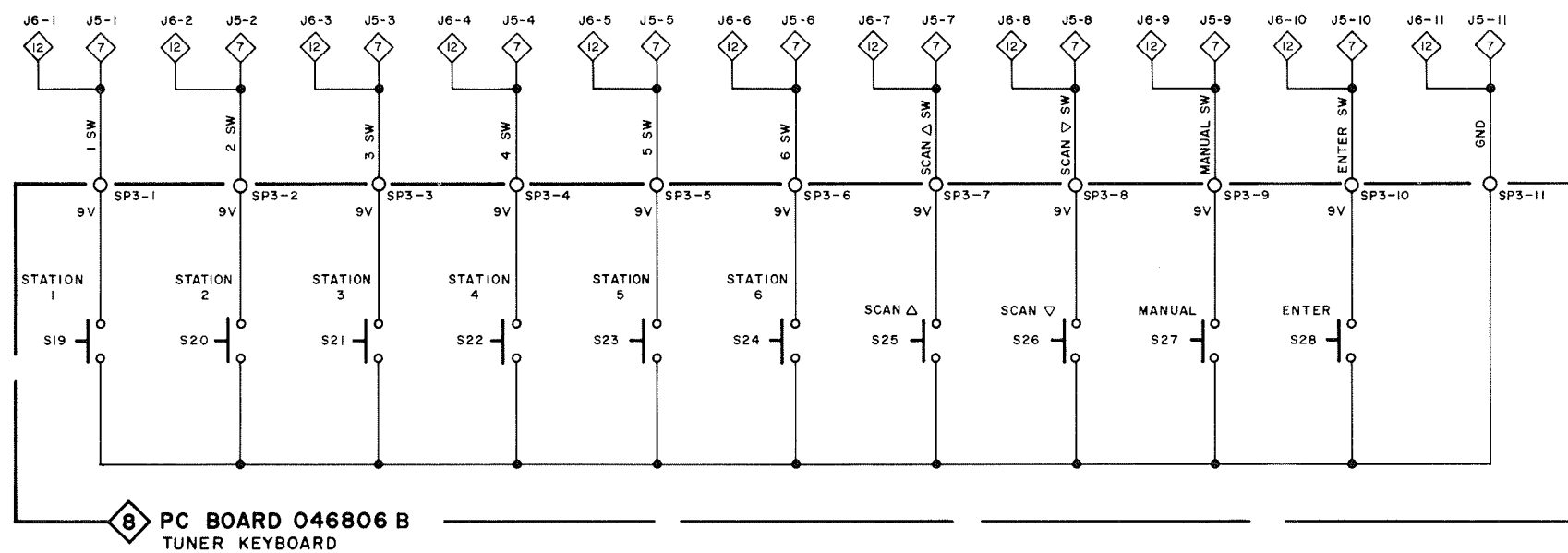

Keyboards 8

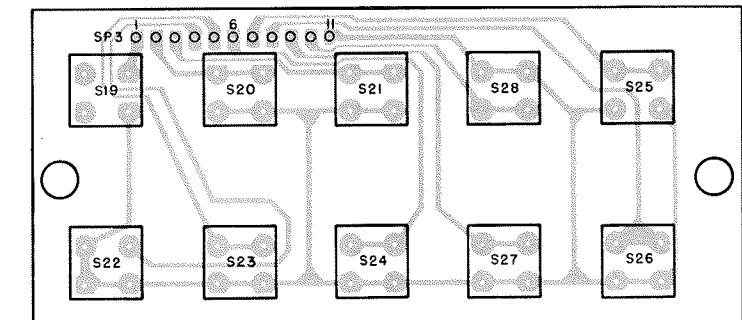

TUNER KEYBOARD PCB 046806 B

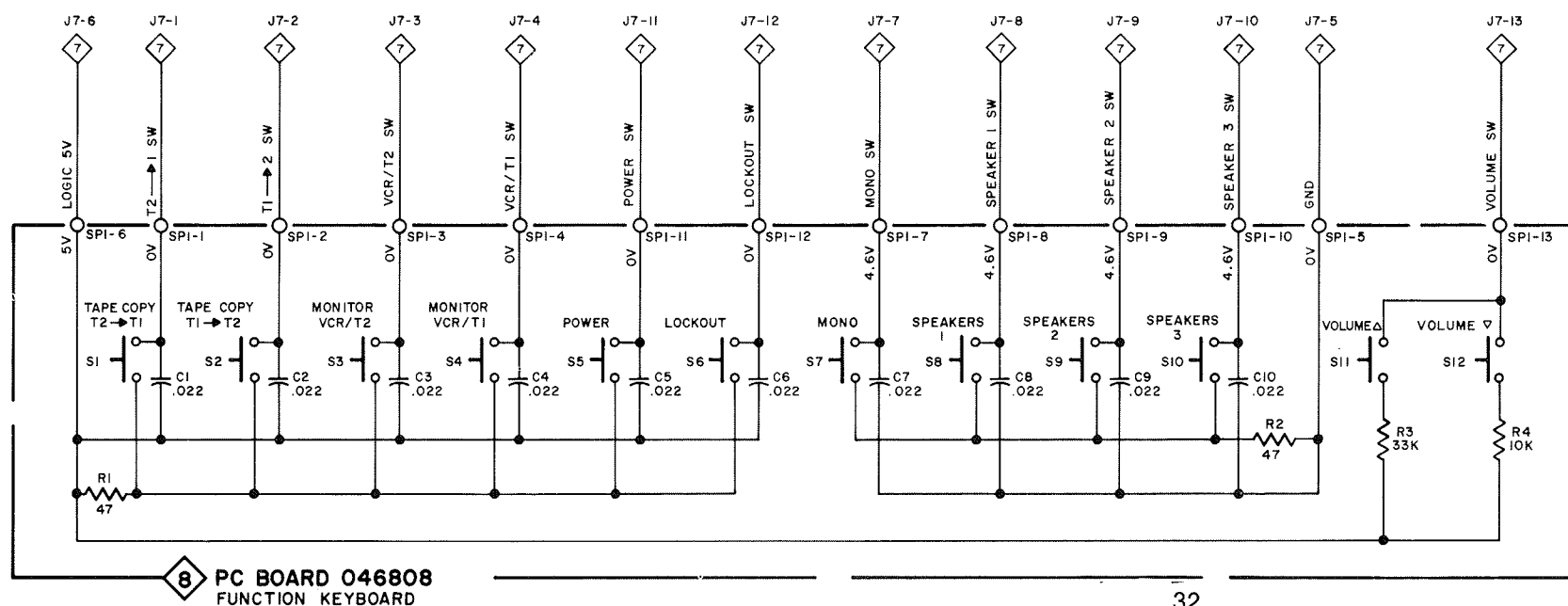

**SECTION 8
PARTS LIST**

Symbol No.	Part No.	Description
SWITCHES		
S1-S28	150052	Pushbutton, Momentary

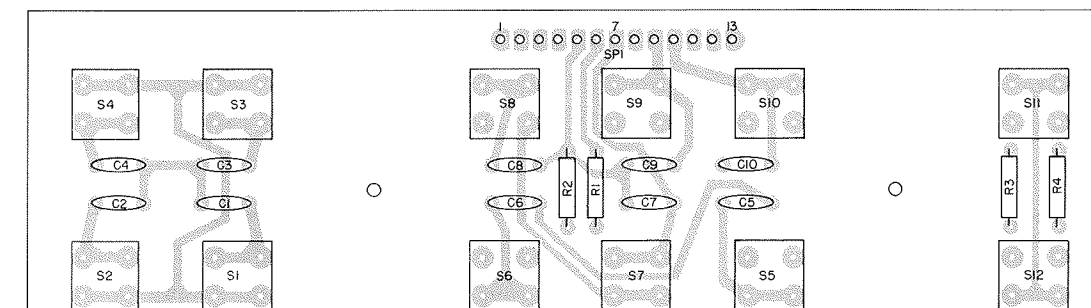

FUNCTION KEYBOARD PCB 046808

9 Power Display

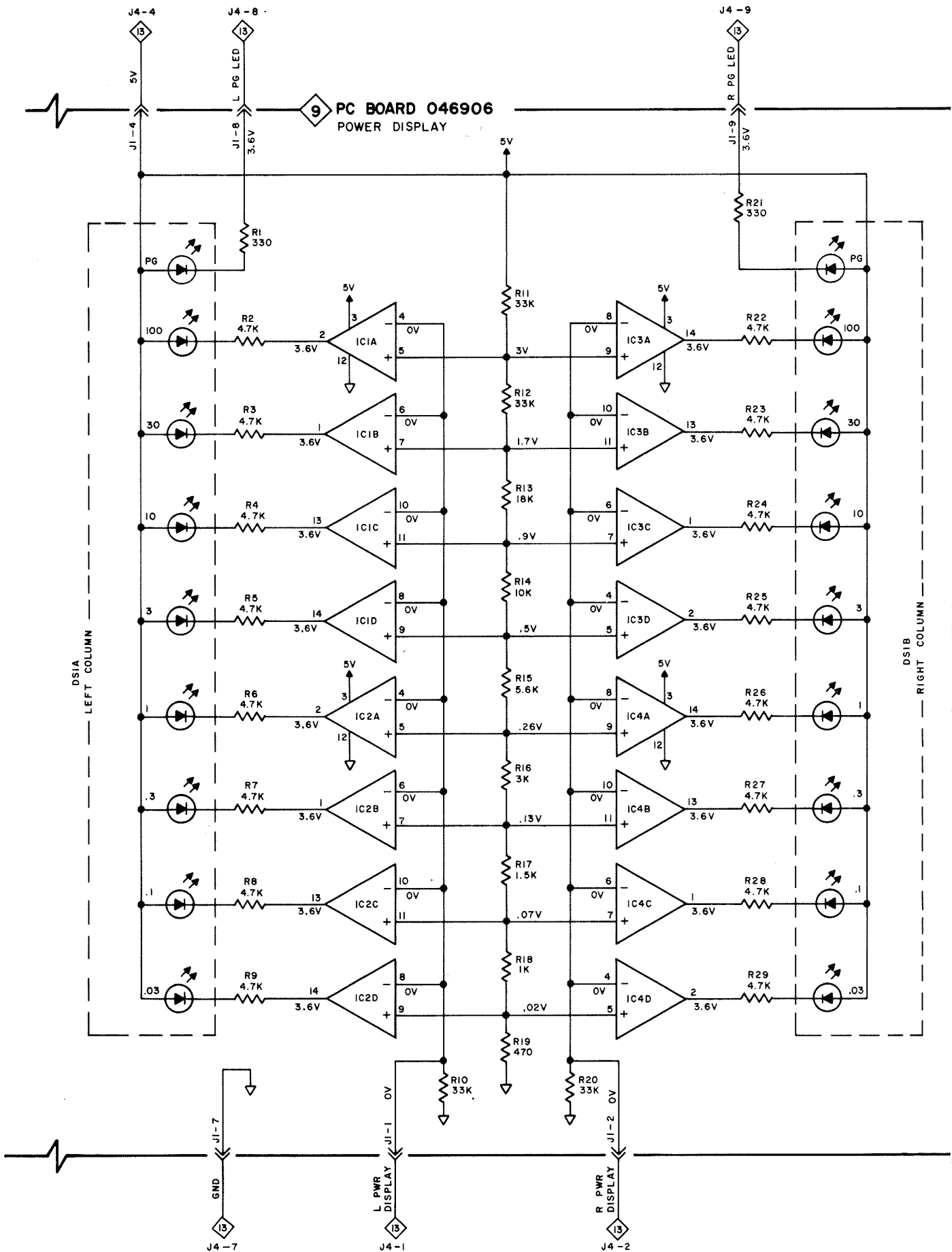

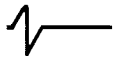

POWER DISPLAY
PORTION OF
PCB 046906

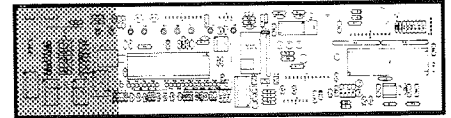

(Only Section 9 Parts Symbol Numbered)

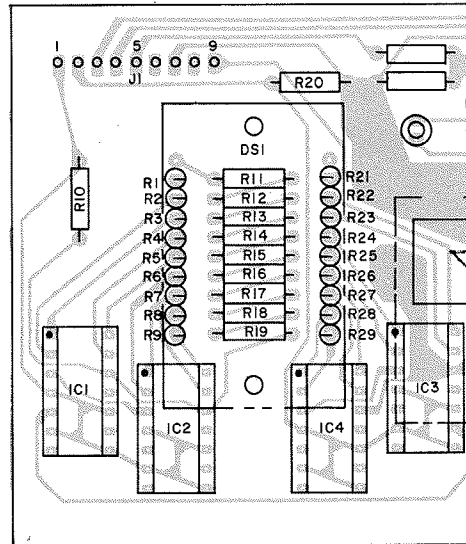

CONTROL/DISPLAY PCB 046906

**SECTION 9
PARTS LIST**

Symbol No.	Part No.	Description
------------	----------	-------------

LIGHTING DEVICES

DS1	070124	Dual 9-Segment Column
-----	--------	-----------------------

INTEGRATED CIRCUITS

IC1-IC4	133092	Quad Comparator, MLM339AP
---------	--------	---------------------------

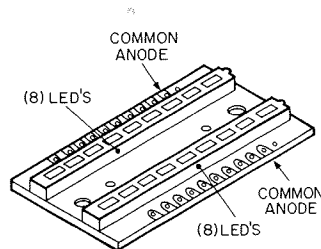

DS1

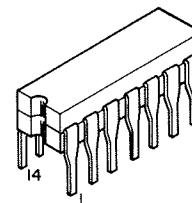

IC1-IC4

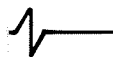

FREQUENCY COUNTER
PORTION OF
PCB 046906

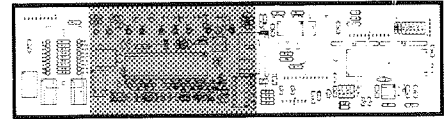

(Only Section 10 Parts Symbol Numbered)

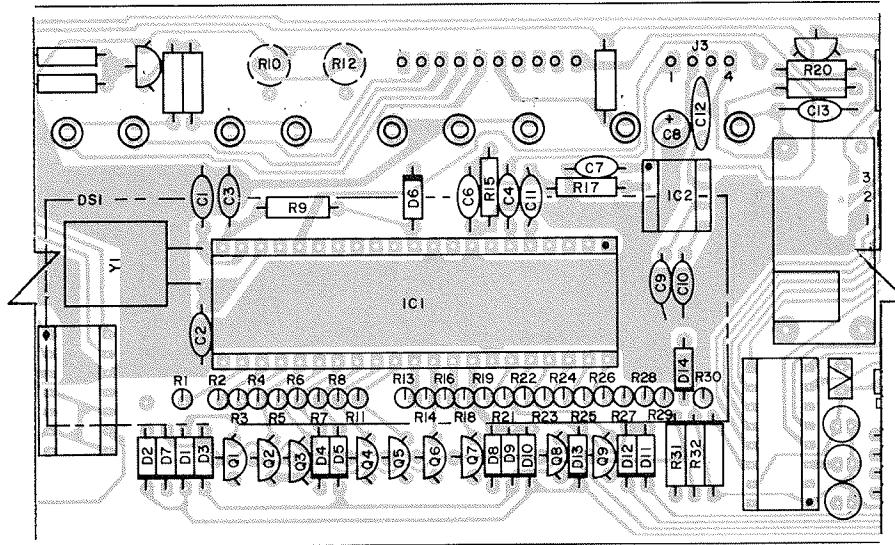

CONTROL/DISPLAY PCB 046906

SECTION 10
PARTS LIST

Symbol No.	Part No.	Description
DIODES		
D1-D14	070047	SIG, 75V, 150mA, 1N4148
LIGHTING DEVICES		
DS1	058084	LED, 7-Segment/4-Digit Display SL-1447

INTEGRATED CIRCUITS

IC1	133106	Counter/Clock/7-Segment Driver LC7250
IC2	133107	ECL, Divide-by-100 Prescaler DS8629N

TRANSISTORS

Q1-Q9	132224	PNP, MPS4126
-------	--------	--------------

CRYSTALS

Y1	180029	Crystal, 4mHz, ±.0025%
----	--------	------------------------

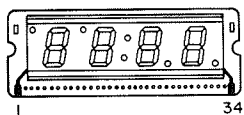

DS1

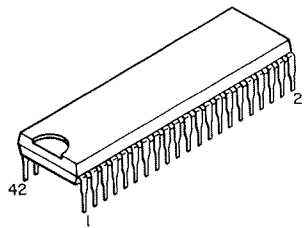

IC1

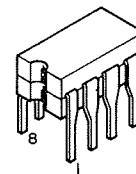

IC2



Q1-Q9

Frequency Counter 10

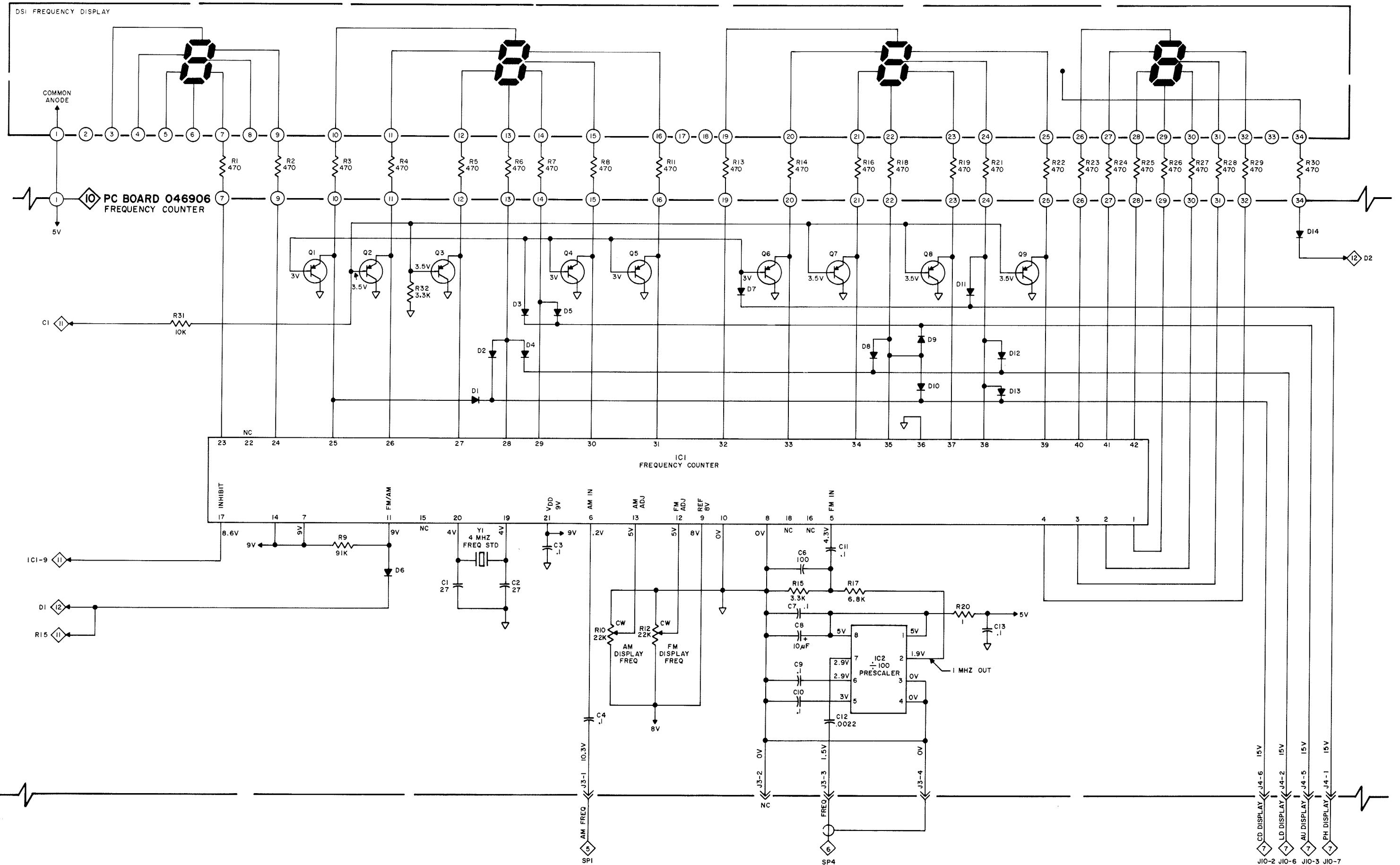

Tuning Voltage Regulator

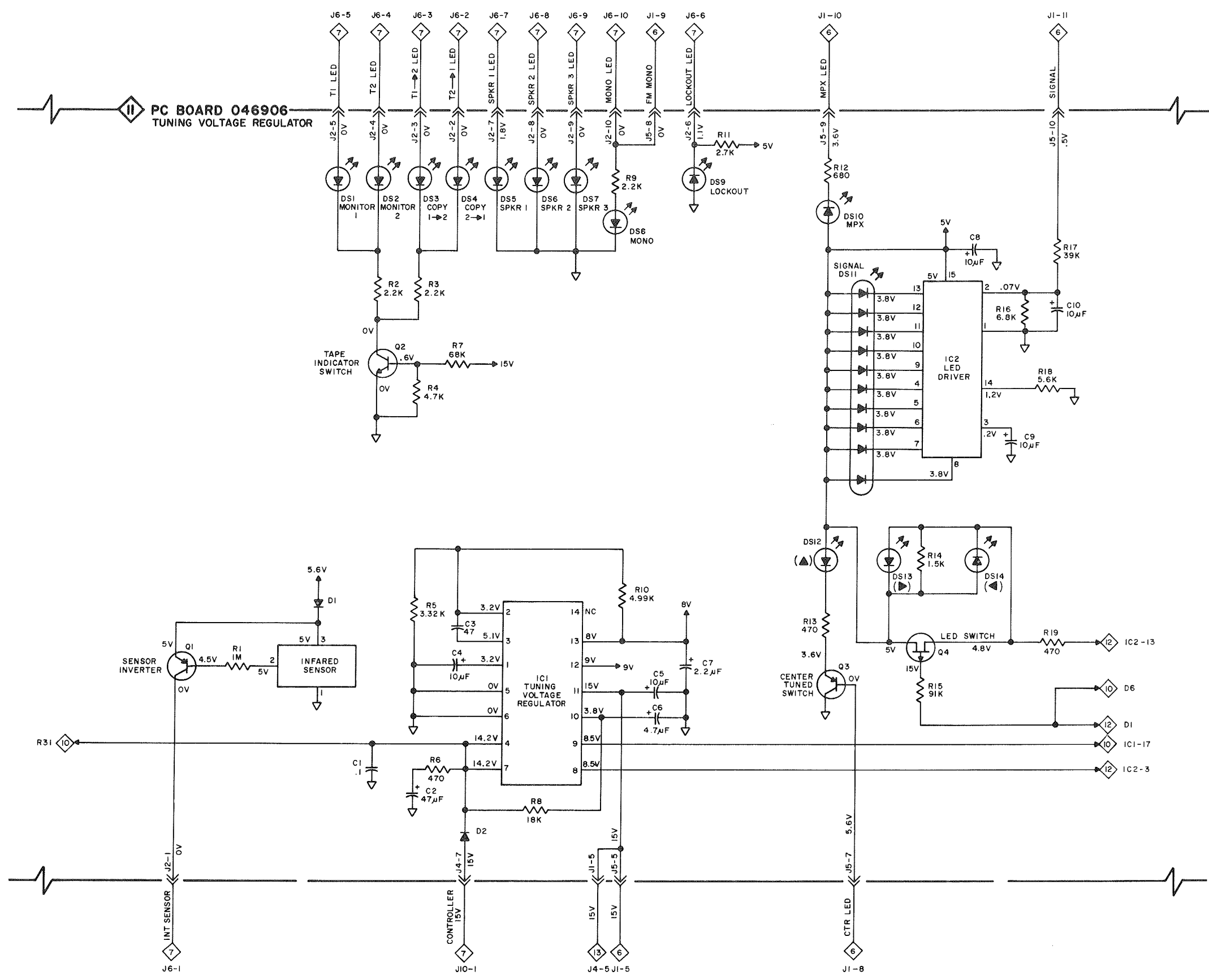

Tuning Voltage Regulator

11

TUNING VOLTAGE
REGULATOR
PORTION OF
PCB 046906

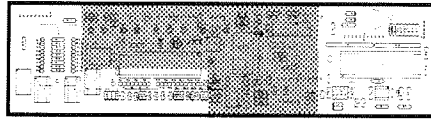

(Only Section 11 Parts Symbol Numbered)

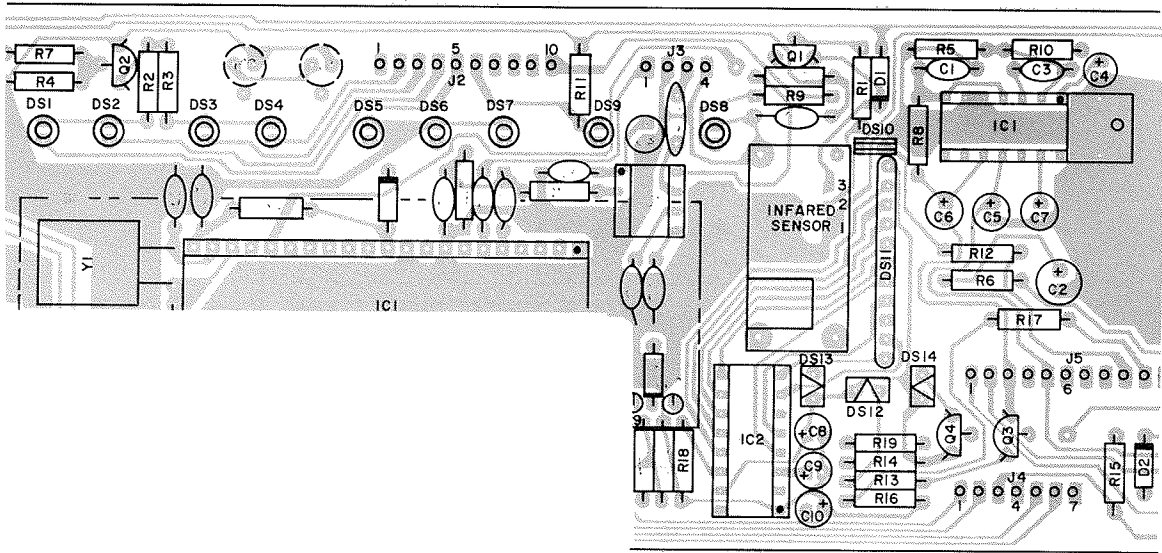

CONTROL/DISPLAY PCB 046906

SECTION 11 PARTS LIST

Symbol No.	Part No.	Description
------------	----------	-------------

DIODES

D1, D2	070047	SIG, 75V, 150mA, 1N4148
--------	--------	-------------------------

LIGHTING DEVICES

DS1-DS9	058078	LED, Red, SLP144B
DS10	070115	LED, Red Bar, AND205R
DS11	045600	LED, 10-Segment Bar on PCB
DS12-DS14	058083	LED, Red Triangle, AND207R

INTEGRATED CIRCUITS

IC1	133104	Tuning Voltage Regulator LA5700
IC2	133118	Level Display Driver LB1411

TRANSISTORS

Q1	132224	PNP, MPS4126
Q2	132223	NPN, MPS4124
Q3	132182	PNP, DAR, MP5A64
Q4	132220	P, FET, J176

SENSORS

121002	Sensor, IR
--------	------------

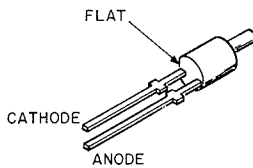

DS1-DS9

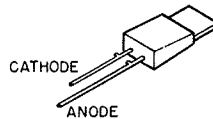

DS10

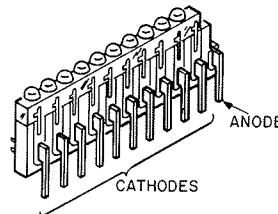

DS11

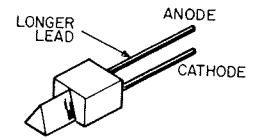

DS12-DS14

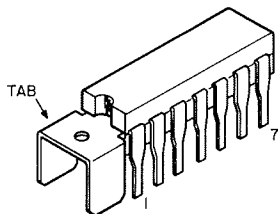

IC1

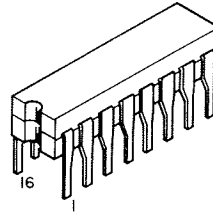

IC2

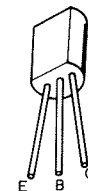

Q1-Q3

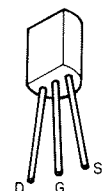

Q4

12

AM/FM Tuning Control

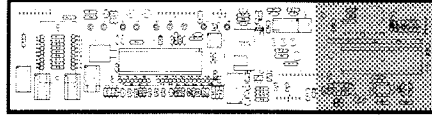

AM/FM
TUNING CONTROL
PORTION OF
PCB 046906

(Only Section 12 Parts Symbol Numbered)

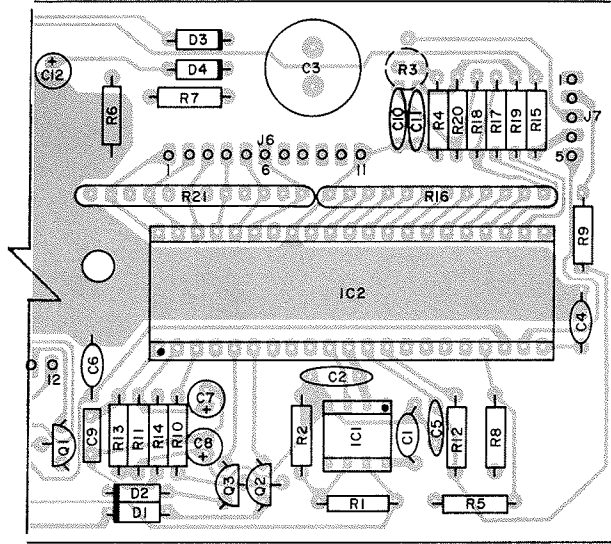

CONTROL/DISPLAY PCB 046906

**SECTION 12
PARTS LIST**

Symbol No.	Part No.	Description
DIODES		
D1-D4	070047	SIG, 75V, 150mA, 1N4148
INTEGRATED CIRCUITS		
IC1	133105	Dual Hi-Speed Operational Amp MC3458P1
IC2	133103	Tuning Control, LC7207
TRANSISTORS		
Q1	132235	NPN, 2SC2240-BL
Q2, Q3	132223	NPN, MPS4124
RESISTORS		
R16	144180	Resistors Network

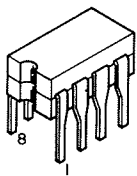

IC1

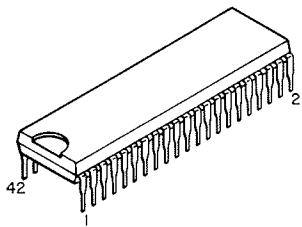

IC2



Q1



Q2-Q3

AM/FM Tuning Control 12

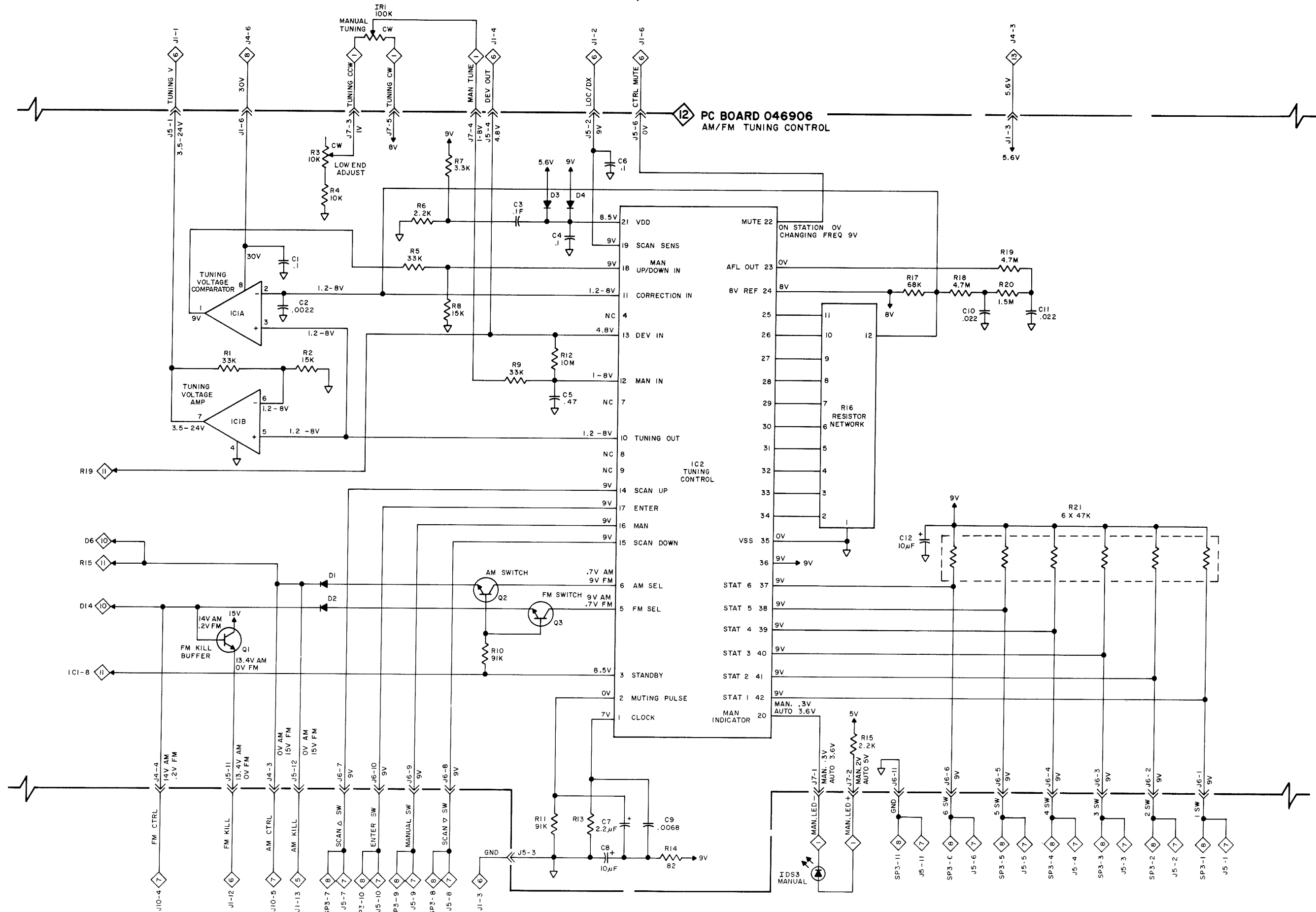

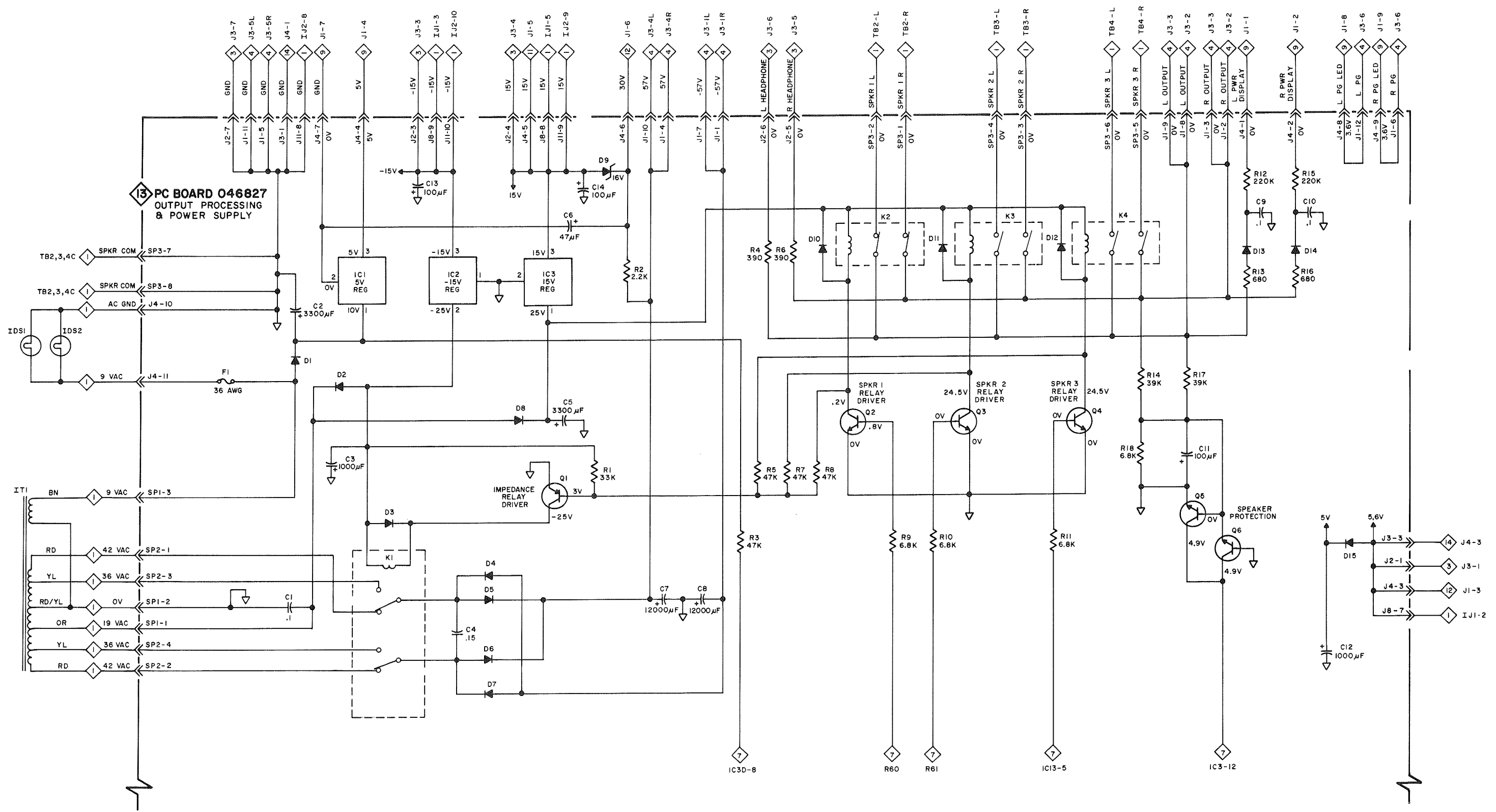

Output Processing and Power Supply

13

OUTPUT PROCESSING AND POWER SUPPLY PORTION OF PCB 046827

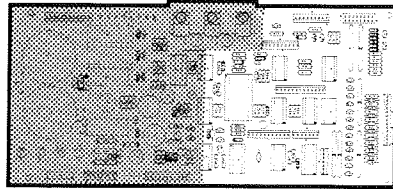

(Only Section 13 Parts Symbol Numbered)

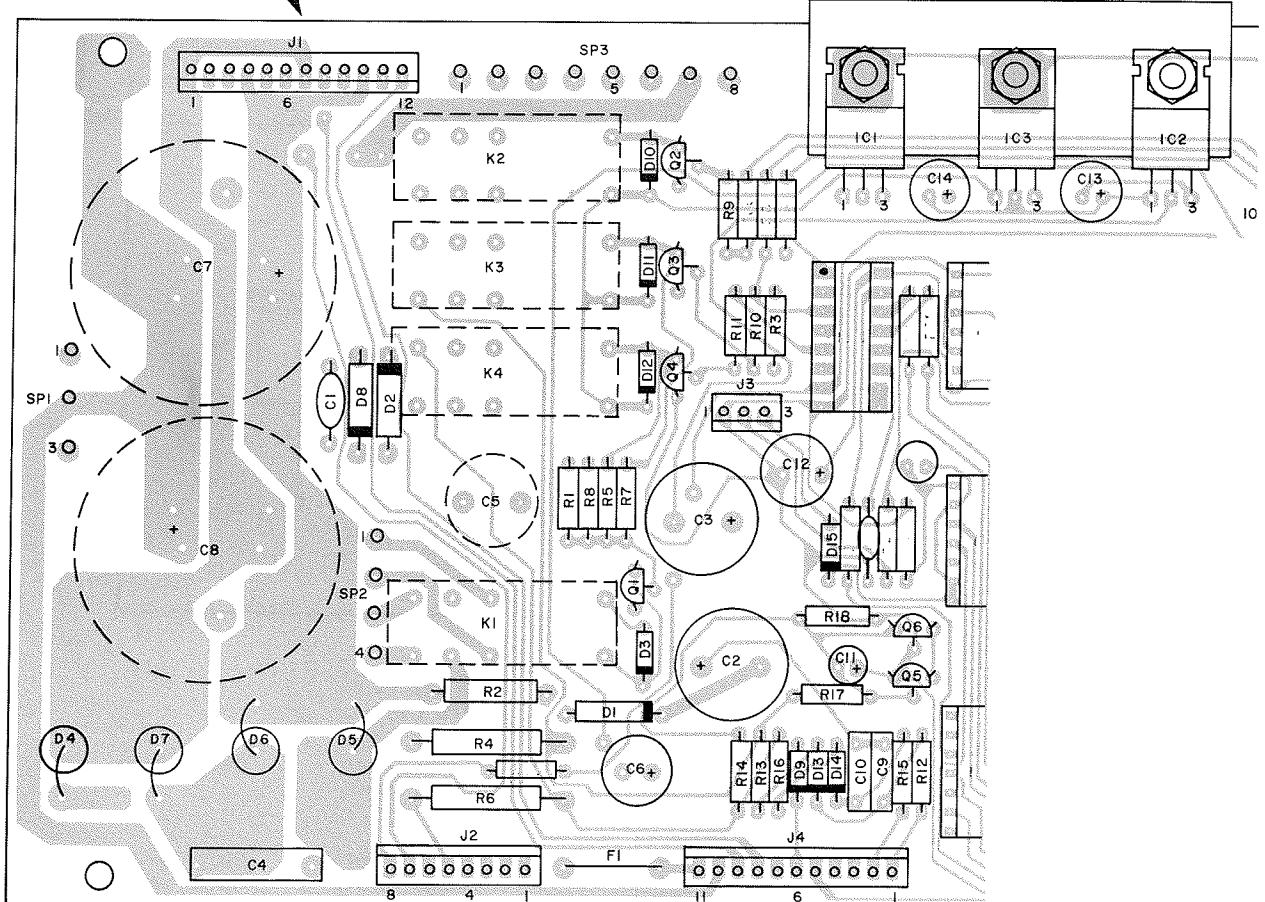

POWER SUPPLY/LOGIC PCB 046827

SECTION 13 PARTS LIST

Symbol No.	Part No.	Description
------------	----------	-------------

CAPACITORS

C7,C8	066393	ELECT, 12,000uF, 63V
-------	--------	----------------------

DIODES

D1,D2	070131	RECT, 400V, 1A, 1N4004
D3	070047	SIG, 75V, 150mA, 1N4148
D4-D7	070133	RECT, 200V, 6A, M7C5
D8	070131	RECT, 400V, 1A, 1N4004
D9	070114	ZN, 16V, 5%, 500mW
D10-D15	070047	SIG, 75V, 150mA, 1N4148

FUSES

F1	174198	Fuse, 36 gauge Tinned Copper Wire
----	--------	-----------------------------------

INTEGRATED CIRCUITS

IC1	133108	+5V Regulator, MC7805CT
IC2	133086	+15V Regulator, MC7815CT
IC3	133087	-15V Regulator, MC7915CT

RELAYS

K1-K4	087043	DPDT, 24VDC
-------	--------	-------------

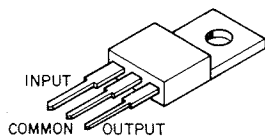

IC1, IC2

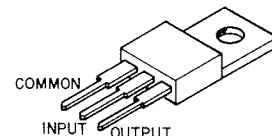

IC3

14

Back-up Power Supply

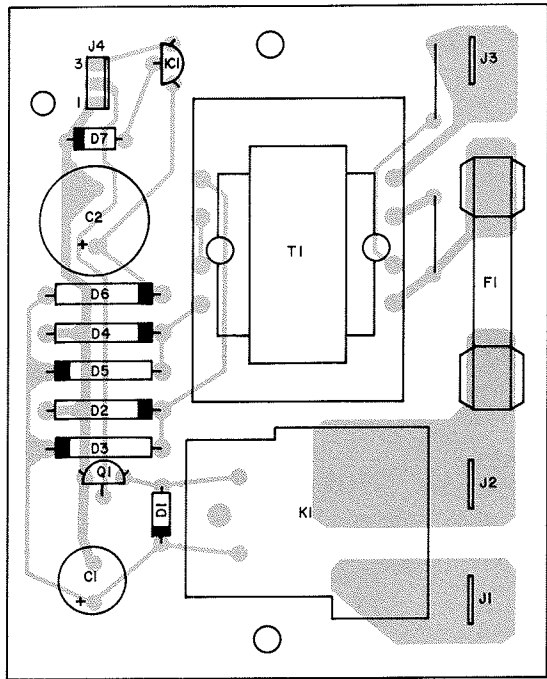
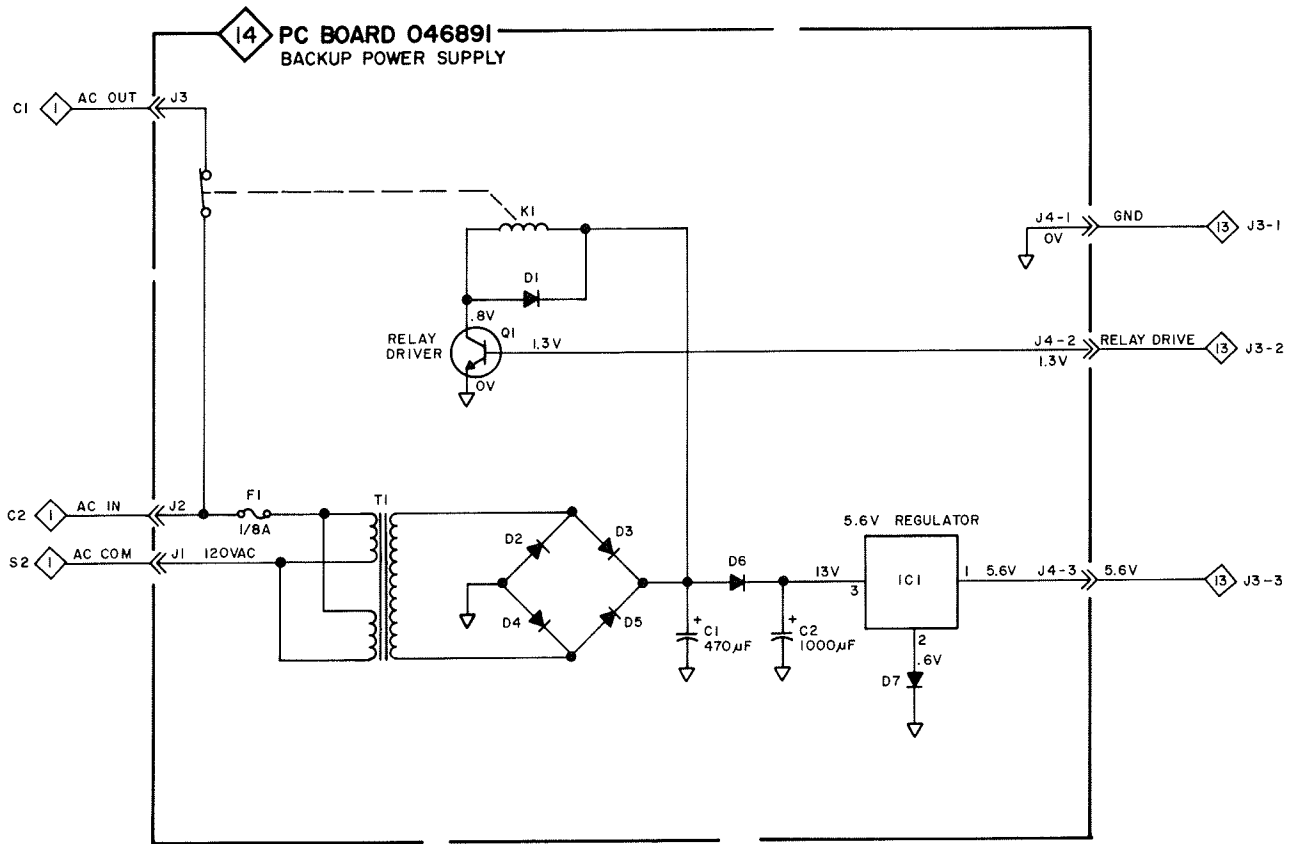

BACK-UP POWER SUPPLY PCB 046891

SECTION 14 PARTS LIST

Symbol No.	Part No.	Description
DIODES		
D1, D7	070047	SIG, 75V, 150mA, 1N4148
D2-D6	070131	RECT, 400V, 1A, 1N4004
FUSES		
F1	089047	Fuse, FA, 1/16A, 250V
INTEGRATED CIRCUITS		
IC1	133093	+5V Regulator, LM7805AC
RELAYS		
K1	087038	SPST, 12VDC
TRANSISTORS		
Q1	132090	NPN, DAR, Selected MPSA14
TRANSFORMERS		
T1	159195	POWER

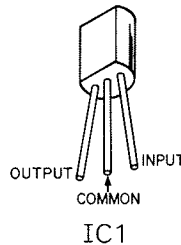

Alignment Procedure

FM ALIGNMENT

Section 12 - AM/FM Tuning Control

1. In FM mode, push the MANUAL button and turn the manual tuning knob fully CCW. Adjust R3 for 3.5VDC at J5, pin 1. If the setting of R3 is changed, the AM alignment must also be checked.

Section 6 - FM Tuner

2. Connect an FM Stereo Signal Generator to the FM ANTENNA input jack.
3. Connect a Distortion Analyzer to the VCR/TAPE 1 outputs.
4. Turn the tuning knob to maximum CCW, then adjust the FM OSC coil (L4) for a frequency display of 87.5MHz.
5. Turn the tuning knob to maximum CW and adjust the FM OSC trimmer capacitor (C16) for a frequency display of 108.5MHz.
6. Repeat Steps 4 and 5 as necessary for the tuning range of 87.5 to 108.5MHz.
7. Tune the generator and receiver to 90MHz and adjust MIXER (L5), RF (L3), and ANT (L1) coils for best sensitivity.
8. Tune the generator and receiver to 104MHz and adjust MIXER (C18), RF (C10) and ANT (C1) trimmer capacitors for best sensitivity.
9. Repeat Steps 7 and 8 until no improvement in sensitivity is noted.
10. Remove the AM/FM tuner cover. With the receiver tuned to 90MHz and no RF input, adjust the DETector PRImary (T3) for 4.8VDC at J1, pin 4.
11. Tune the generator to 90MHz. Adjust the RF output to 1000uV and 100% mono modulation at 1000Hz. Adjust the DETector SEcOnDary (T2) for lowest distortion.
12. Reduce the generator output to minimum and detune the generator so the receiver picks up only noise, then recheck the voltage at J1, pin 4. If it is not 4.8 ± 0.2 VDC, repeat step 10 and 11. If there is interference from a station on this frequency, tune the receiver to a nearby frequency free from interference for this measurement.
13. Turn the STEREO BLEND pot (R32) fully CW. Connect a Frequency Counter to TP1 and adjust 19kHz (R21) for a frequency of $19 \pm .05$ kHz.
14. Tune the generator to 90MHz with a 1000uV output. Switch the generator to stereo (left only) and adjust the IF INPUT transformer (T1) for the lowest distortion at the Left VCR/TAPE 1 output.
15. Adjust the SIGNAL STRENGTH pot (R54) CW to the point where all 10 LED dots are lit.
16. Switch the analyzer to the right VCR/TAPE 1 output and adjust the Right MPX SEParation pot (R13) for best separation (minimum output).
17. Switch the generator to the right channel and the analyzer to the left channel. Adjust the Left MPX SEParation pot (R15) for best separation. (minimum output)
18. Reduce the generator output to 50uV and adjust the STEREO BLEND pot (R32) for 20dB separation.
19. Reduce the generator output to 2.5uV and adjust the MUTING/STEREO SWITCH pot (R48) so the MPX light just comes on.

Section 10 - Frequency Counter

20. Remove the generator and connect an antenna. Tune to a station of known frequency and check for proper frequency display. If necessary, adjust the FM DISPLAY FREQ pot (R12) for the correct frequency reading.

AM ALIGNMENT

Section 12 - AM/FM Tuning Control

1. In AM mode, push the MANUAL button and turn the manual tuning knob fully CCW. Adjust R3 for 3.5VDC at J5, pin 1. If the setting of R3 is changed, the FM alignment must also be checked.

Section 5 - AM Tuner (remove cover)

2. Connect an AM Signal Generator to the IF INJECTION (TP2). Connect a Distortion Analyzer to the VCR/TAPE 1 OUTPUT.
3. Set the generator frequency to 455 ± 0.5 kHz and modulate 30% at 400Hz. Increase the RF output to 10,000uV and adjust the AM DET OFFSET (T2) for 4.8VDC at J1, pin 4.
4. Reduce the RF output to 1000uV or less. Adjust the AM MIXER transformer (T5) for maximum audio at the VCR/TAPE 1 OUTPUT. Disconnect TP2.
5. Turn the manual tuning knob to maximum CCW and adjust the AM OSC coil (T1) for a frequency display of 535kHz.
6. Turn the tuning knob to maximum CW and adjust the AM OSC trimmer capacitor (C18) for a frequency display of 1620kHz.
7. Repeat Steps 5 and 6 as necessary for the tuning range of 535kHz to 1620kHz.
8. Connect the generator to the AM ANTENNA and GND Terminals.
9. Tune the generator and receiver to 600kHz, then adjust the RF (T3) and MIXER (T4) coils for best sensitivity.
10. Tune the generator and receiver to 1400kHz, then adjust RF (C19), and MIXER (C27) trimmer capacitors for best sensitivity.
11. Repeat Steps 9 and 10 until no improvement in sensitivity is noted.

Section 10 - Frequency Counter

12. Disconnect the generator and connect an antenna. Tune with a SCAN button to a station of known frequency and check for proper frequency display. If necessary, adjust the AM DISPLAY FREQ pot (R10) for the correct frequency reading.

POWER AMPLIFIER BIAS

Section 4 - Power Amplifier

1. Operate the MAC4300V for 5 minutes or longer with no audio output.
2. Connect Digital Voltmeter test leads to TP1 and TP2 on the Heat Sink PC board. Take precautions to prevent accidental shorts which may damage the amplifier.
3. Adjust the BIAS pot (R31) for 7-10mV.
4. Perform steps 2 and 3 for the other channel.

Repacking Instructions

In the event it is necessary to return the MAC4300V to McIntosh Laboratory for service, the unit must be packed exactly as shown below.

The four plastic feet must be attached to the bottom of the MAC4300V so they will locate in the four holes of the base pad.

If a shipping carton is needed, please call or write the Customer Service Department of McIntosh Laboratory. Order using the part numbers on the accompanying list.

Use the original shipping carton only if all pads and cartons are in good serviceable condition.

QTY	PART NO.	DESCRIPTION
1	033475	Shipping carton only
1	033449	Foam pad
1	033258	Foam sheet
1	033454	Bottom pad
4	033333	Corner pad
2	033350	Butterfly pad
4	017218	Bottom cover feet
4	100159	#10 x 3/4 screw for 017218
1	101014	#10 x 1-3/4 screw for 033454
1	104033	#10 flat washer for 101014
1	033451	Inside carton only
1	046941	Shipping carton complete

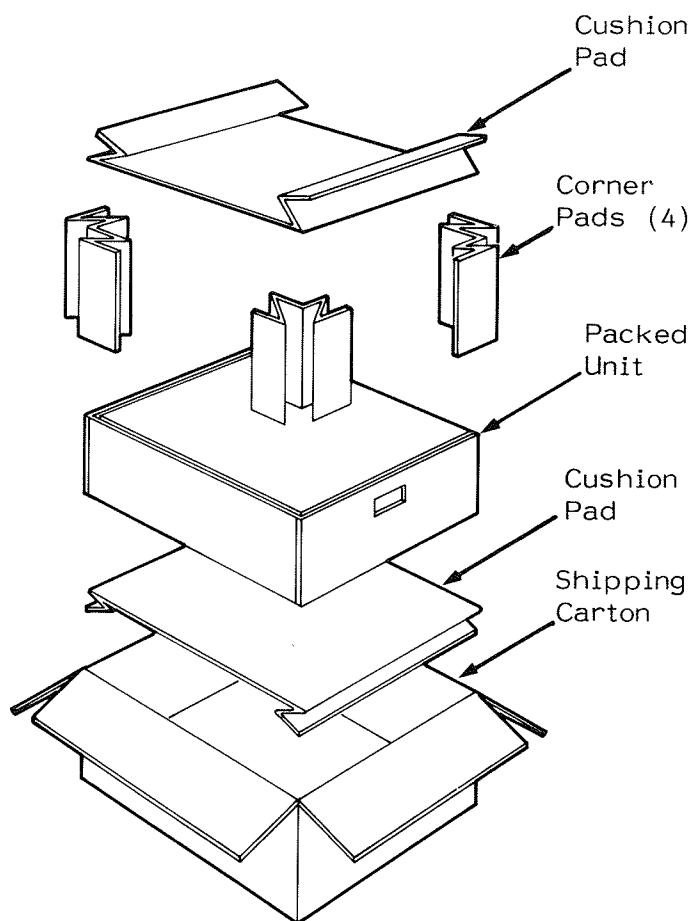
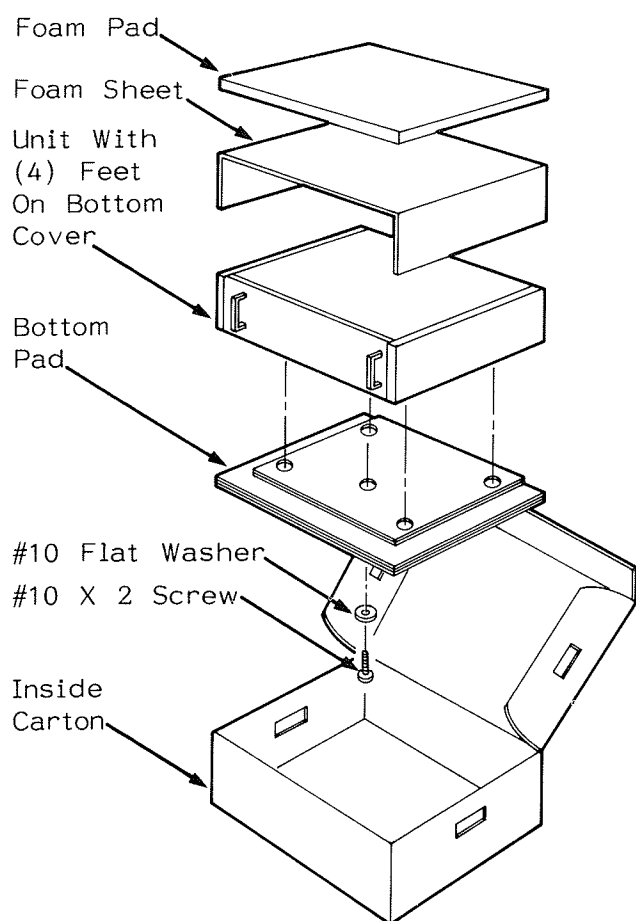

McIntosh®

MAC4300V AM/FM RECEIVER

The continuous improvement of its products is the policy of McIntosh Laboratory Incorporated, who reserve the right to improve design without notice. Because of the constant upgrading of McIntosh products' circuitry and components, the Company cannot insure, and does not warrant, the accuracy of the within schematic material, which is intended for information only.

McIntosh Laboratory Inc. 2 Chambers Street Binghamton, NY 13903-2699

Part No. 039667

Printed in U.S.A.

607-723-3512